

TECHNICAL DRAWING 2

WELDER

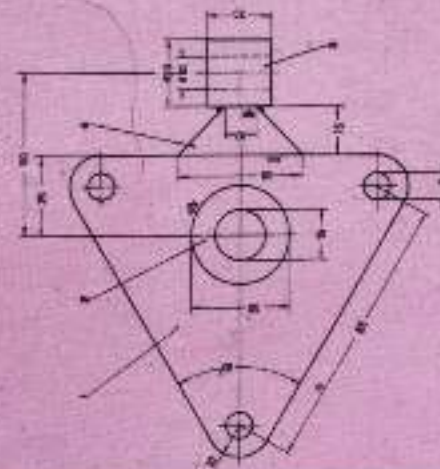

GOVERNMENT OF THE PUNJAB
TECHNICAL EDUCATION & VOCATIONAL TRAINING AUTHORITY
TRADE TESTING BOARD
DEVELOPMENT CELL LAHORE

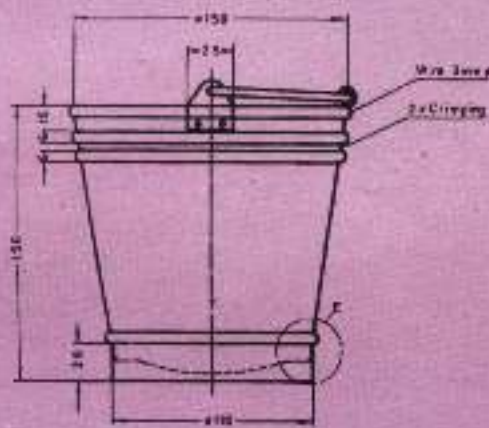
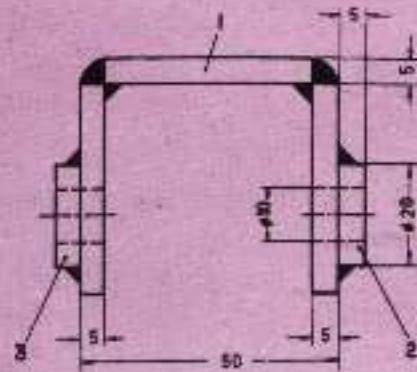
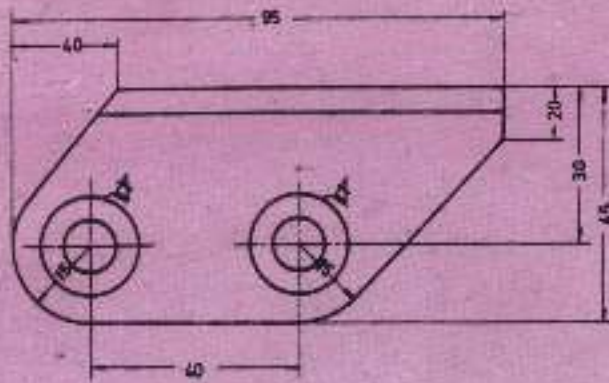

T.T.P. Series No. 70

Price: 50.00

CONTENTS

DRAWING NO:

BENT PARTS

Support	1
Sheet Metal Strap	2

DEVELOPMENTS

Cup	3,1,3,2
Square-pipe knee	4,1,4,2
Square-pipe off-set knee	5,1,5,2
Truncated pipe	6,7
Pipe knee	8,1,8,2
Pyramid	9,1,9,2
Frustum of a pyramid	10,1,10,2
Frustum of a cone	11
Truncated cone	12
Tinned sheet funnel	13
Galvanized	14
Spirit bottle	15,1,15,2
Bucket	16

INFORMATION SHEETS

Welding symbols	17
Representation of welded joints	18
Welding symbols	19

WELDED SHEETS

Lever	20
Welded gear blank	21,1,21,2
Spring bracket	22
Bearing	23
Lever	24
Bracket	25
Flange bearing	26
Angle Support	27
Welded screw clamp	28,1,28,2
Pipe line	29,1,29,2
Pivot	30,1,30,2
Brake disk	31
Clamping plate	32
Angle	33
Bracket	34
Welded 'Z'	35
Eye type bearing	36
High pressure tank	37
Welded stand	38
Angler bearing	39,1,39,2
Drilling jig	40,1,40,2
Brake cylinder	41,1,41,2

Prepared and published under the Pakistan – German Technical Training Programme by:
DEVELOPMENT CELL FOR SKILLED LABOUR TRAINING
8 / A, Abu Bakar Block, New Garden Town, Lahore – 16.

Printed by: **ECONOMICAL PRESS,**
Urdu Bazar, Lahore. Ph: 042-37246928

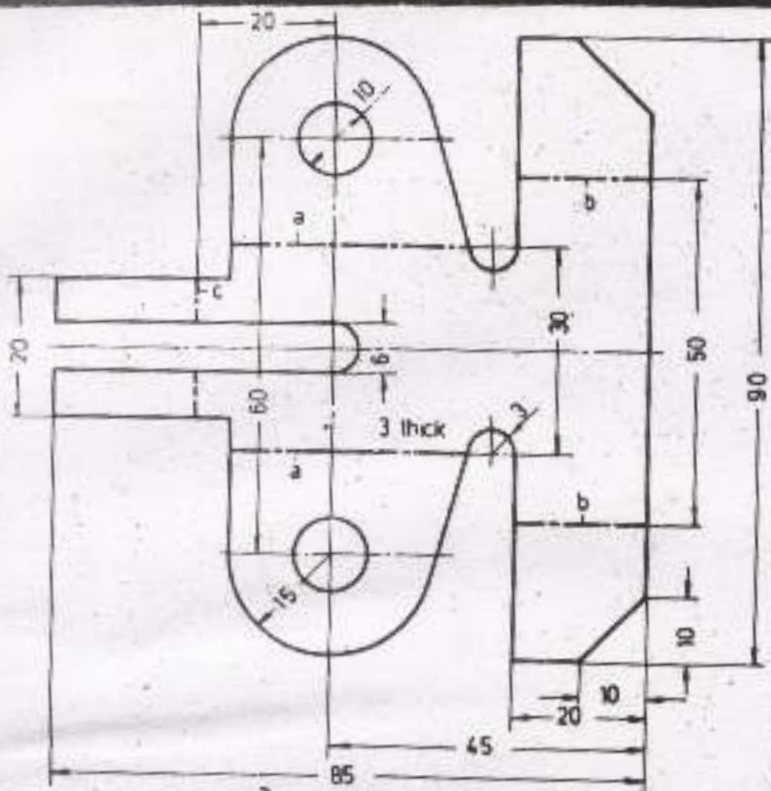

Bend the sheetmetal downwards at a right angle on the bending lines „a“ (dot-and-dash-lines) Internal width 30 mm
 Bend upwards on bending lines „b“ and „c“, inside distance |b| 50 mm and |c| 20 mm from hole center
 Bending radius 3mm

Task:
 Draw the resultant workpiece in three views Scale 1:1

Scale 1:1	SUPPORT		Bent parts
Date	Name		WELDER
 DEVELOPMENT CELL FOR SKILLED LABOUR TRAINING PAK-GERMAN TECHNICAL TRAINING PROGRAMME			Technical Drawing No.1

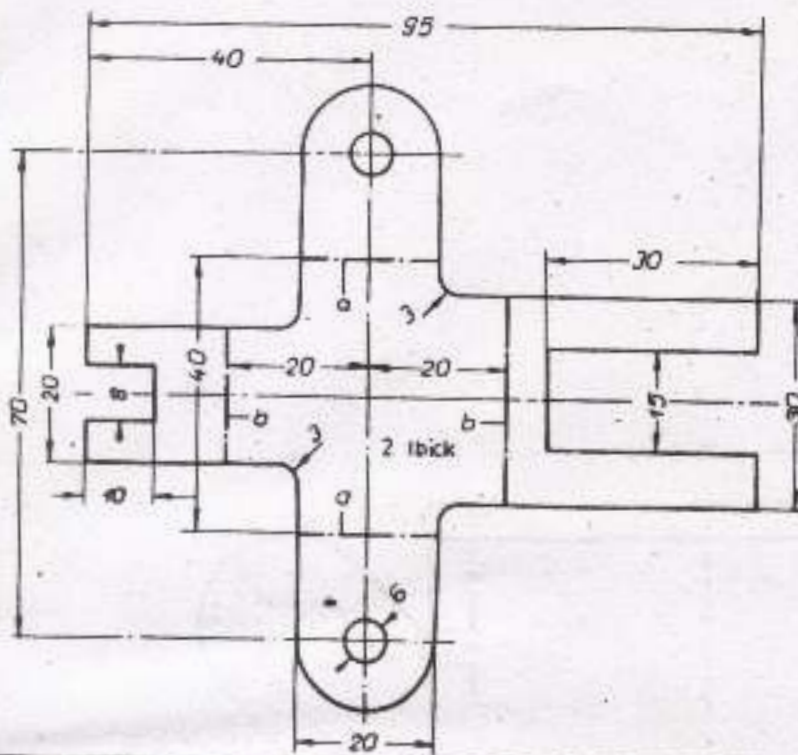

Bend the sheet metal upwards on the bending lines „a“ (sharp corner) internal width 40 mm and downwards on bending lines „b“ (sharp corner) internal width 40 mm

Task

Draw the resultant workpiece in three views. Scale 1:1.

Scale 1:1	SHEET METAL STRAP		Bent parts
Date	Name		WELDER
 DEVELOPMENT CELL FOR SKILLED LABOUR TRAINING PAK-GERMAN TECHNICAL TRAINING PROGRAMME			Technical Drawing No. 2

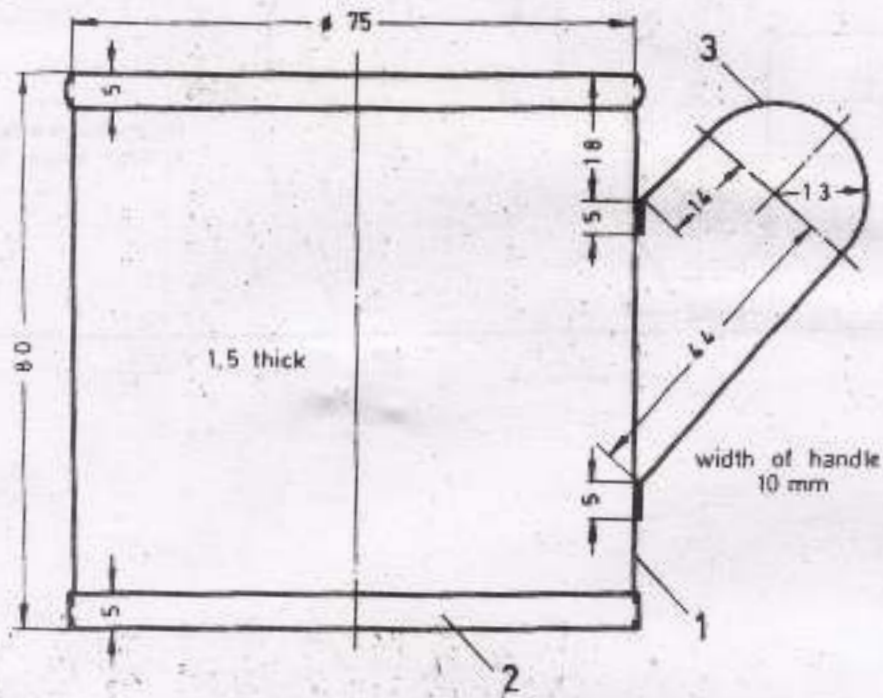

Task:

Prepare full size developments of the three parts on sheet no. 3.2

Scale 1:1	CUP	Developments
Date	Name	WELDER
 DEVELOPMENT CELL FOR SKILLED LABOUR TRAINING PART-GERMAN TECHNICAL TRAINING PROGRAMME		Technical Drawing No. 3.1

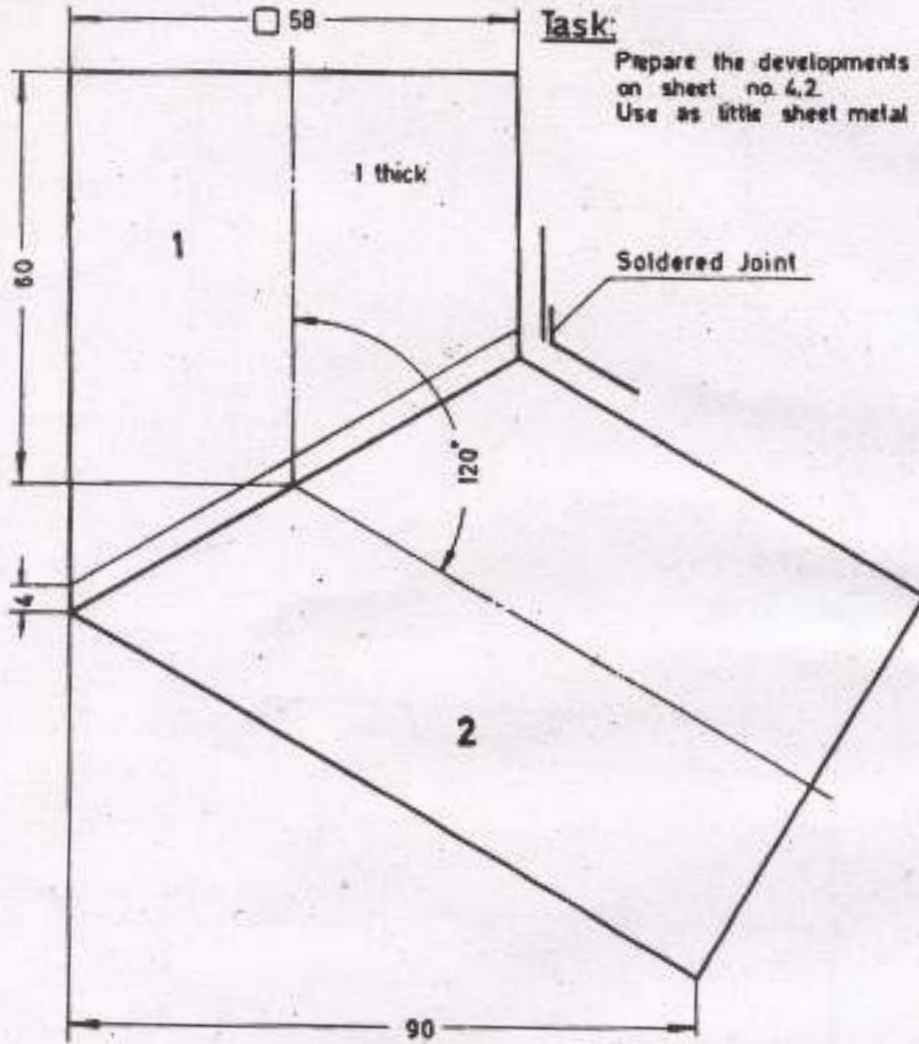

Task:

Prepare the developments of the two parts on sheet no. 4.2. Use as little sheet metal as possible.

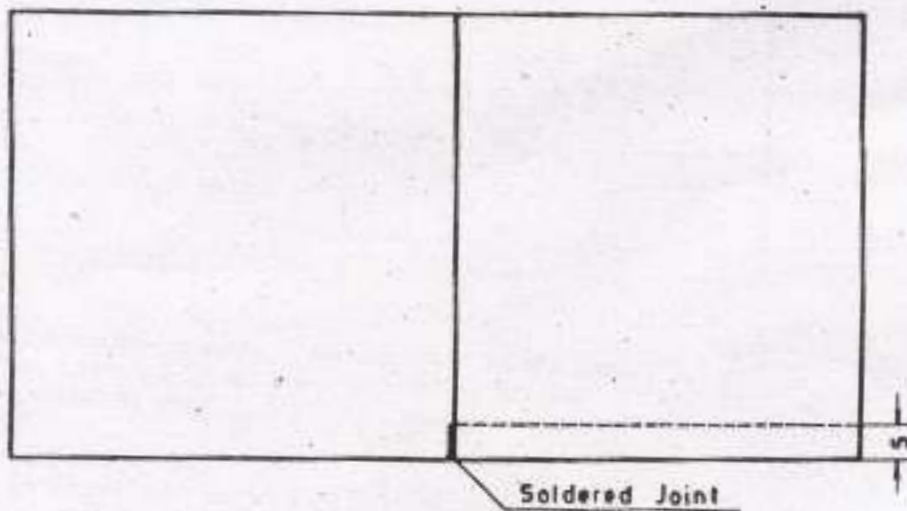

Scale 1:1	SQUARE-PIPE KNEE	Developments
Date	Name	WELDER
 DEVELOPMENT CELL FOR SKILLED LABOUR TRAINING P&K-GERMAN TECHNICAL TRAINING PROGRAMME		Technical Drawing No. 4,1

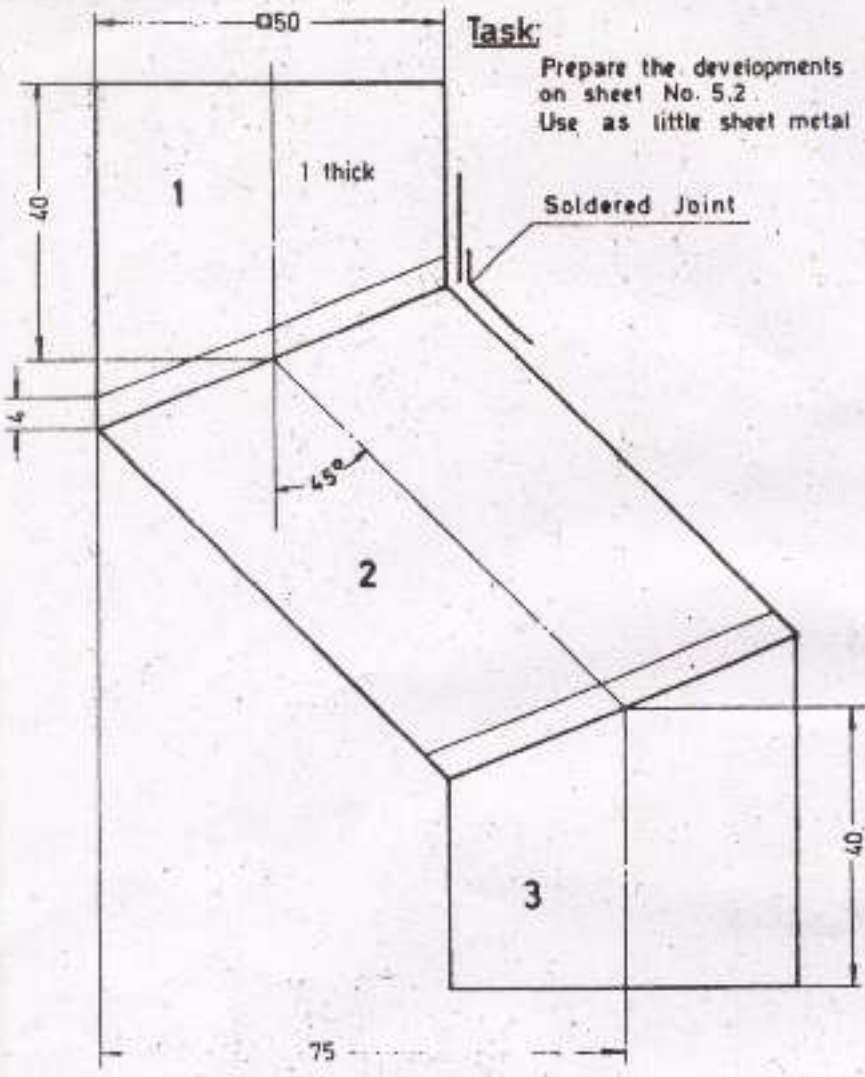

Task:
 Prepare the developments of the three parts
 on sheet No. 5.2.
 Use as little sheet metal as possible.

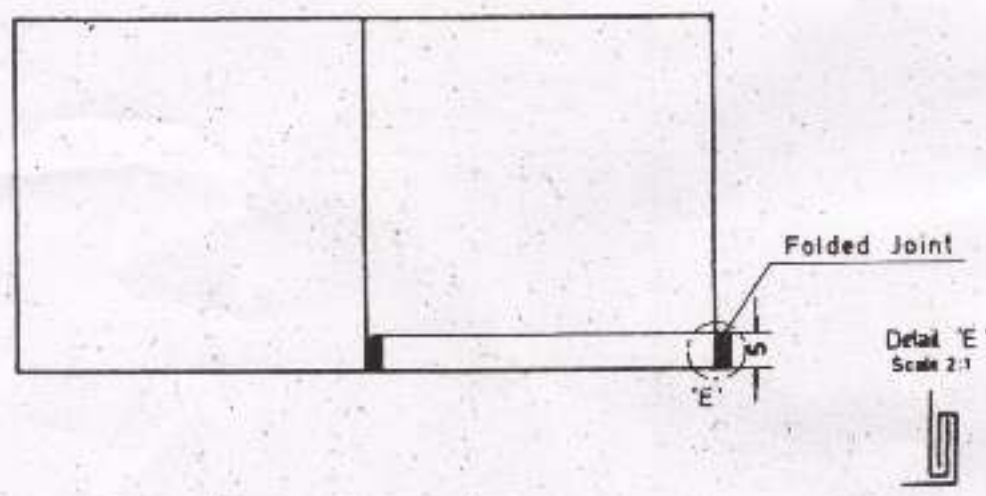

Scale 1:1	SQUARE PIPE OFF-SET KNEE	Developments
Date	Name	WELDER

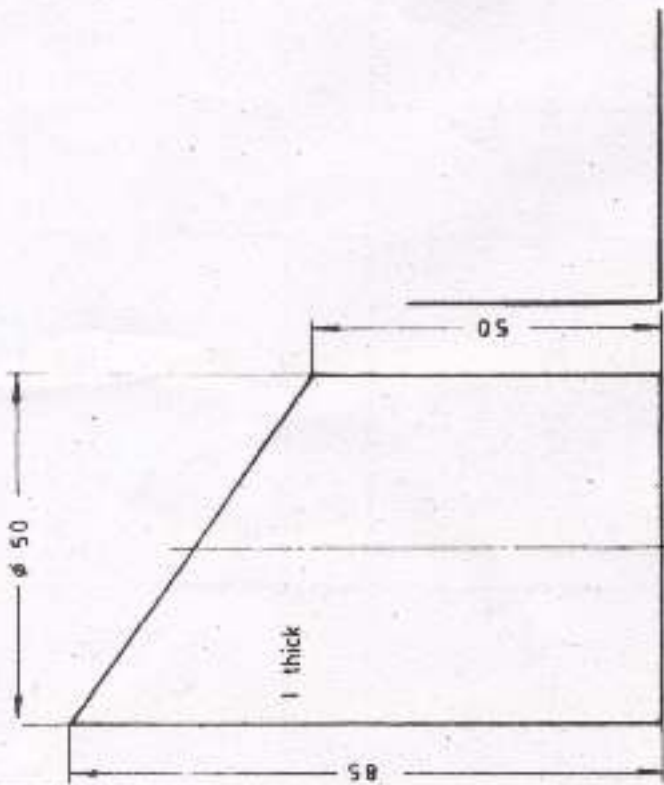

Task: Prepare the development.

Scale 1:1	TRUNCATED PIPE	Developments
Date		WELDER
 DEVELOPMENT CELL FOR SKILLED LABOUR TRAINING PAK-GERMAN TECHNICAL TRAINING PROGRAMME		Technical Drawing No. 6

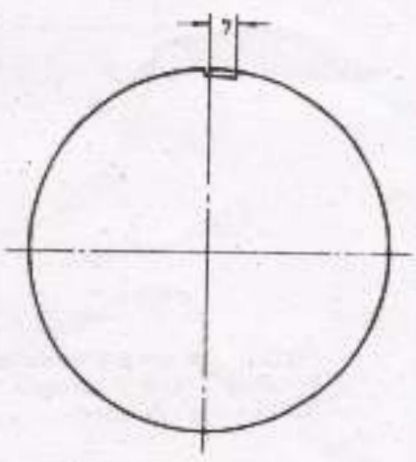
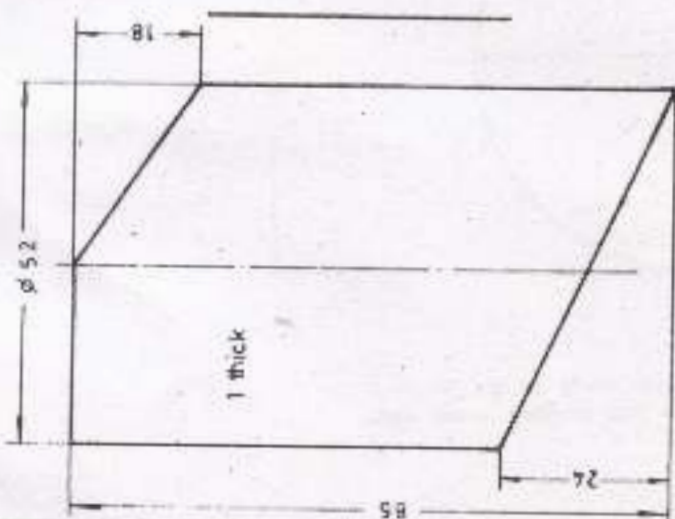

Task: Prepare the development.

Scale 1:1	TRUNCATED PIPE	Developments
Date	Name	WELDER
 DEVELOPMENT CELL FOR SKILLED LABOUR TRAINING PAK-GERMAN TECHNICAL TRAINING PROGRAMME		Technical Drawing No 7

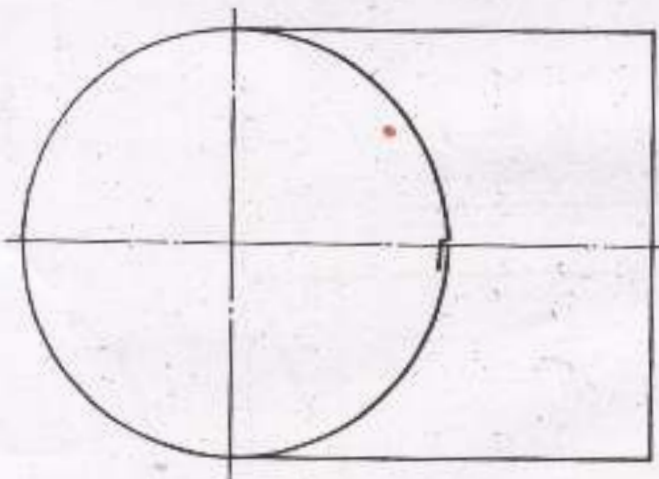
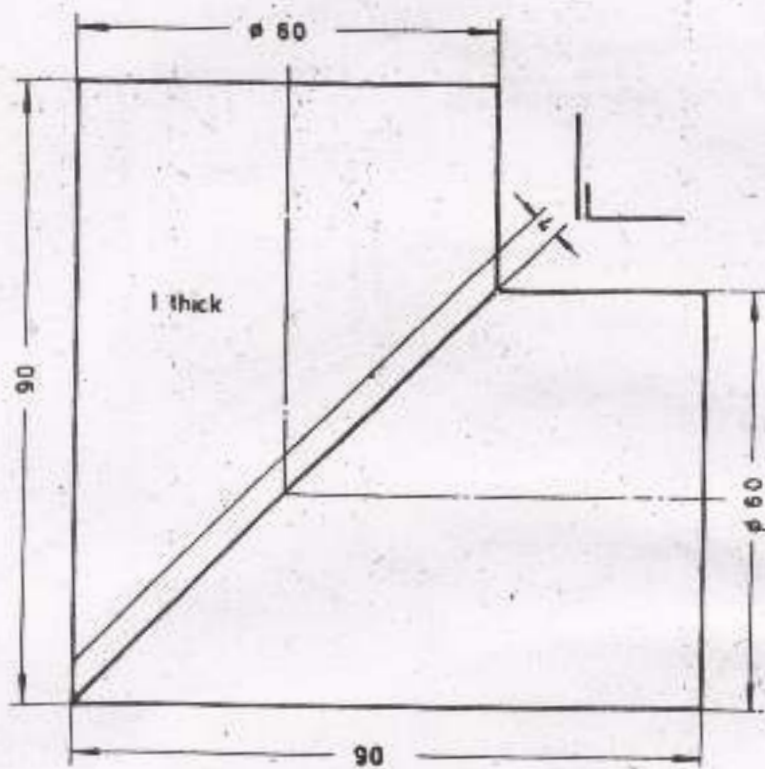

Task:

Prepare the developments of the two parts of the knee on sheet No 8.2 in such a way that as little sheet metal as possible is used.

Scale 1:1	PIPE KNEE	Developments
Date	Name	WELDER
 DEVELOPMENT CELL FOR SKILLED LABOUR TRAINING PAK GERMAN TECHNICAL TRAINING PROGRAMME		Technical Drawing No. 8.1

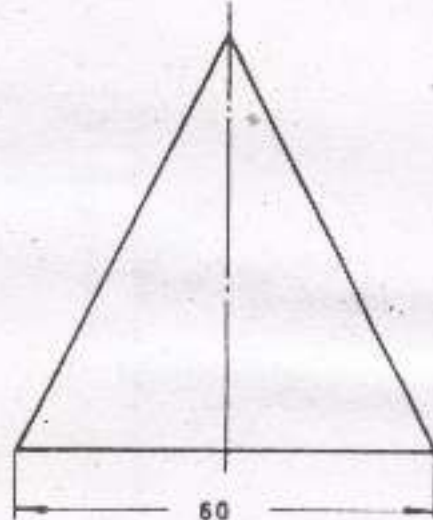
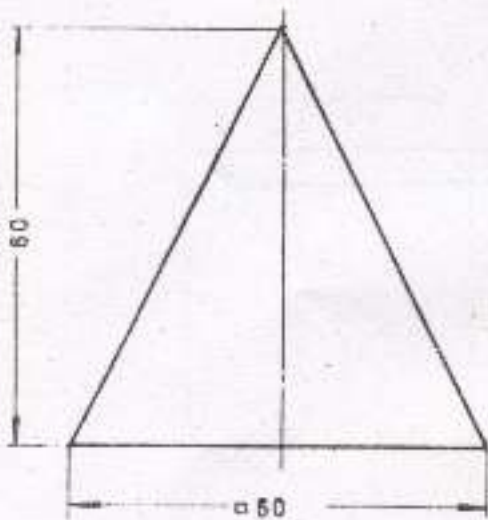

Task:

Draw the plan view and prepare the development of the pyramid on sheet No 9.2.

Scale 1:1	PYRAMID.	Developments
Date	Name	WELDER
 DEVELOPMENT CELL FOR SKILLED LABOUR TRAINING PAK-GERMAN TECHNICAL TRAINING PROGRAMME		Technical Drawing No.9.1

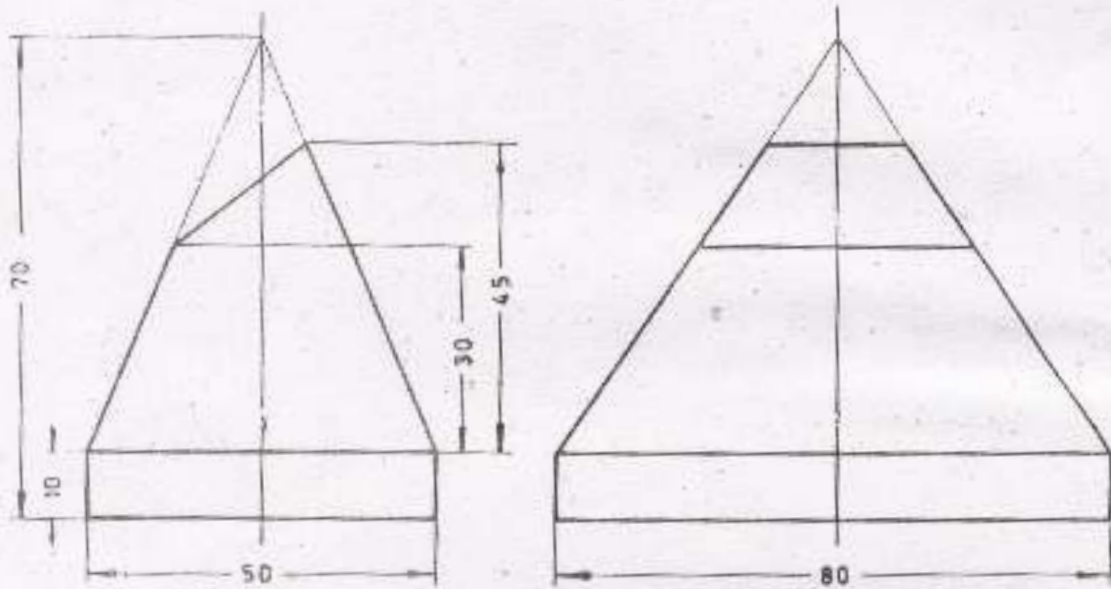

Task:

Draw the plan view and prepare the development of the pyramid on the sheet No.10.2.

Scale 1:1	FRUSTUM OF A PYRAMID	Development
Date	Name	WELDER
	DEVELOPMENT CELL FOR SKILLED LABOUR TRAINING	Technical Drawing
	PAK-GERMAN TECHNICAL TRAINING PROGRAMME	No.10.1

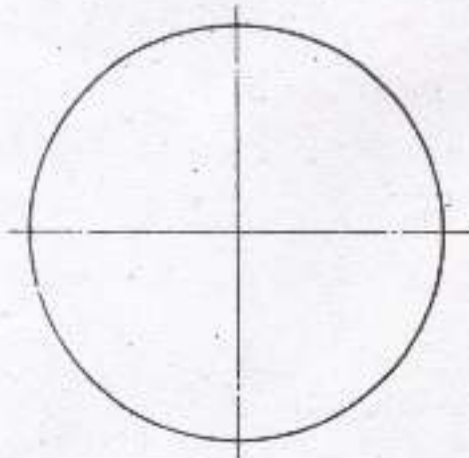
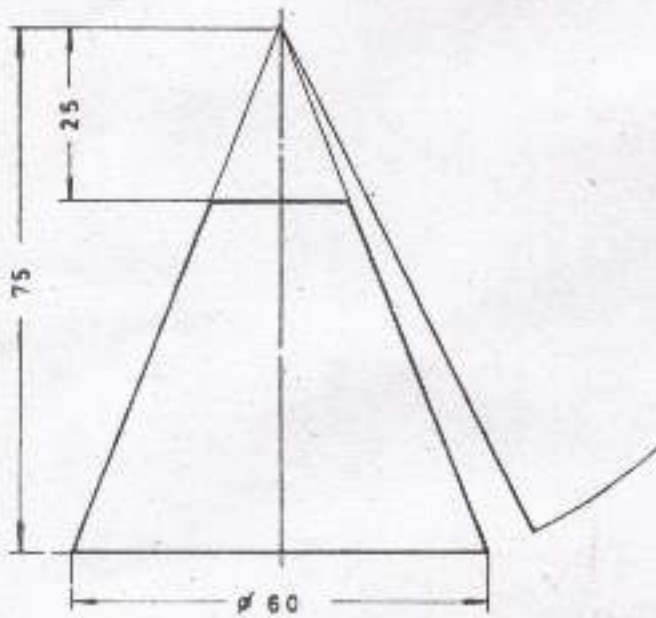

Task:

Complete the plan view and prepare the development.

Scale 1:1	FRUSTUM OF A CONE	Developments
Date	Name	WELDER
 DEVELOPMENT CELL FOR SKILLED LABOUR TRAINING PART GERMAN TECHNICAL TRAINING PROGRAMME		Technical Drawing No. 11

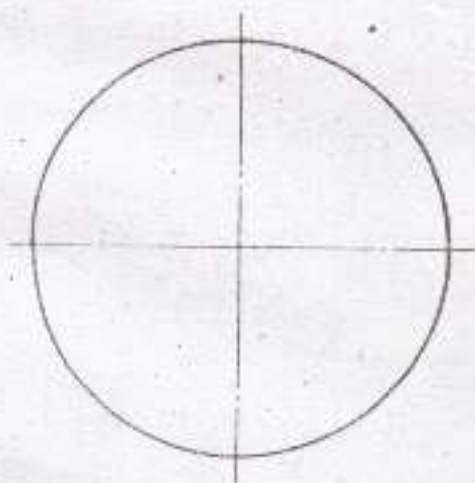
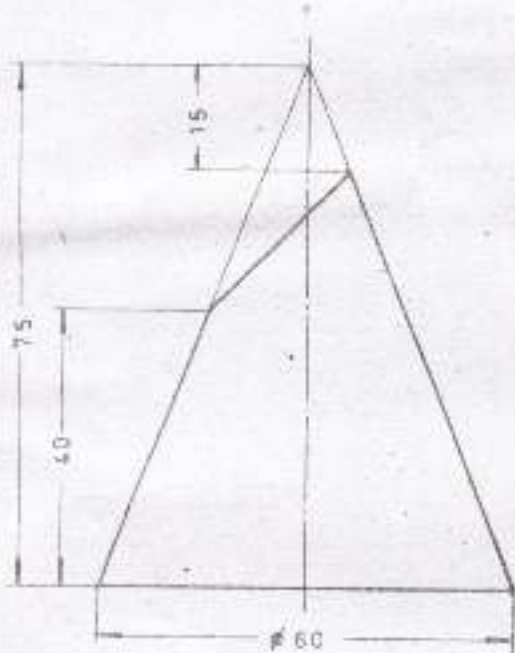

Task:

Complete the plan view and prepare the development.

Scale 1:1	TRUNCATED CONE	Developments
Date	Name	WELDER
 DEVELOPMENT CELL FOR SKILLED LABOUR TRAINING <small>FAK-GERMAN TECHNICAL TRAINING PROGRAMME</small>		Technical Drawing No 12

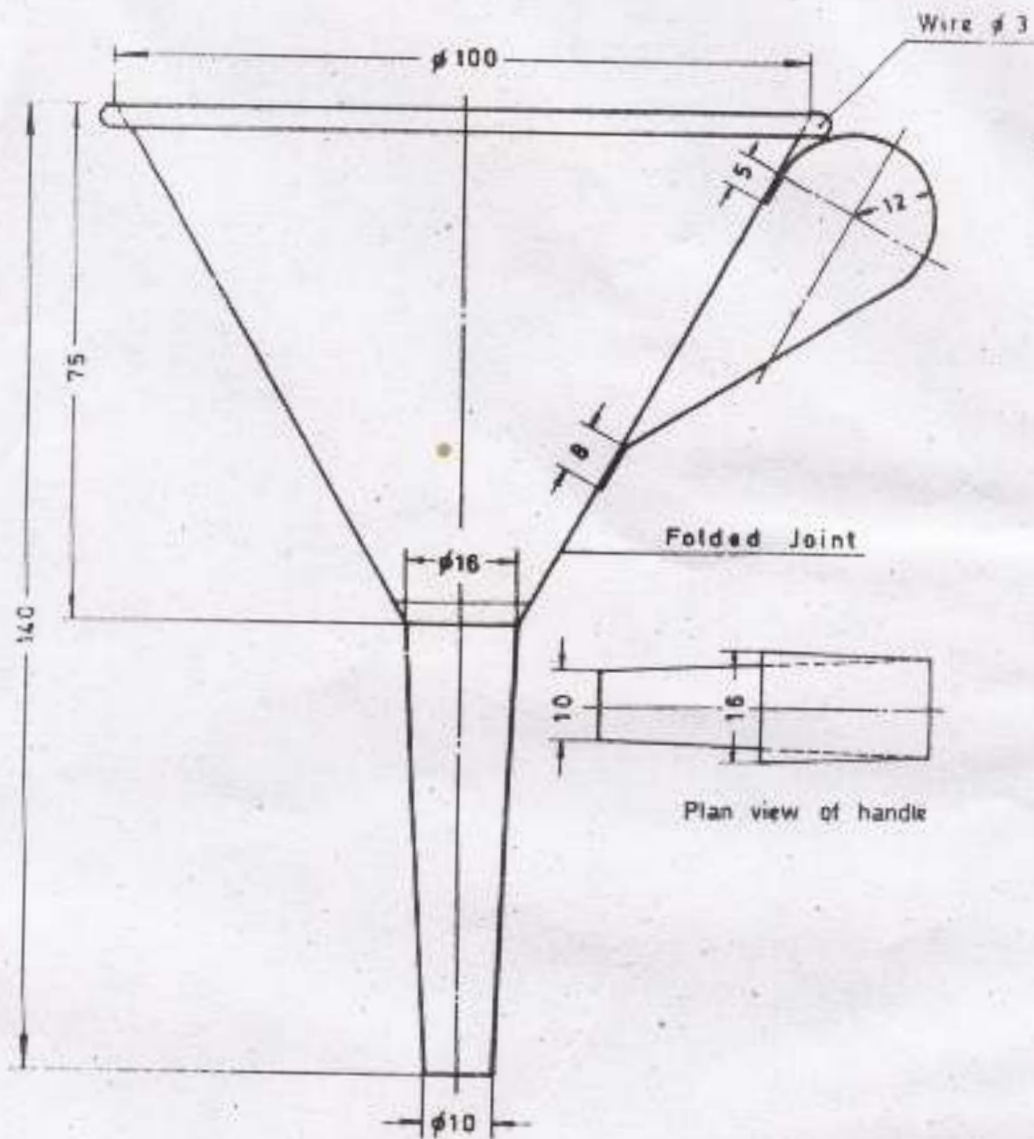

Task:

Copy this drawing on a A3 size sheet.
 Draw the plan view and prepare the developments
 of the body, the taper pipe and the handle.

Scale 1:1.	TINNED SHEET FUNNEL	Developments
Date	Name	WELDER
 DEVELOPMENT CELL FOR SKILLED LABOUR TRAINING PAK-GERMAN TECHNICAL TRAINING PROGRAMME		Technical Drawing No. 13

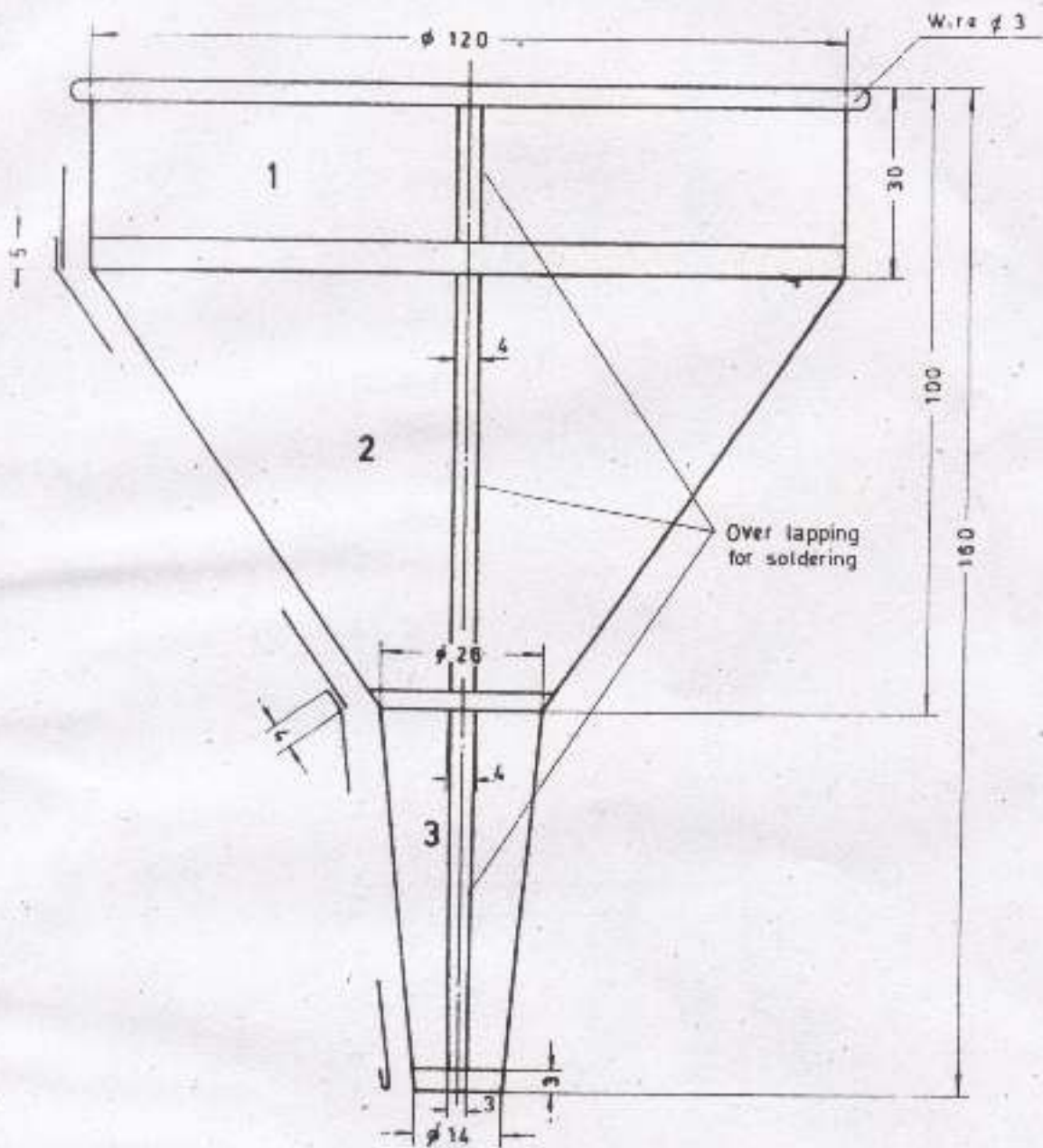

Task:

Copy this drawing on a A3 size sheet.
 Draw the plan view and prepare the development
 of parts 1, 2 and 3.

Scale 1:1	GALVANIZED SHEET FUNNEL	Developments
Date	Name	WELDER
 DEVELOPMENT CELL FOR SKILLED LABOUR TRAINING PAK-GERMAN TECHNICAL TRAINING PROGRAMME		Technical Drawing No. 14

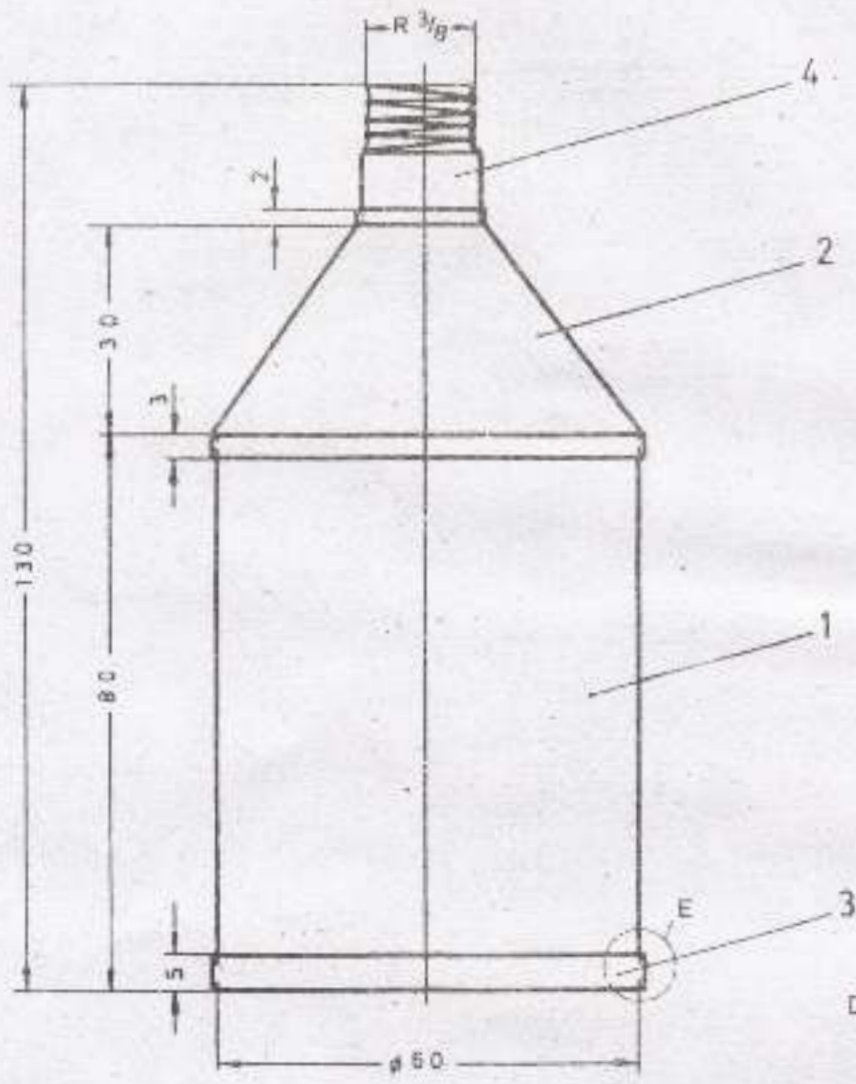

Detail 'E'
Scale 2:1

Task:

Prepare the developments of parts 2 and 3 on sheet No. 15.2.

Scale 1:1	SPIRIT BOTTLE	Developments
Date	Name	WELDER
 DEVELOPMENT CELL FOR SKILLED LABOUR TRAINING <small>FAK - GERMAN TECHNICAL TRAINING PROGRAMME</small>		Technical Drawing No. 15.1

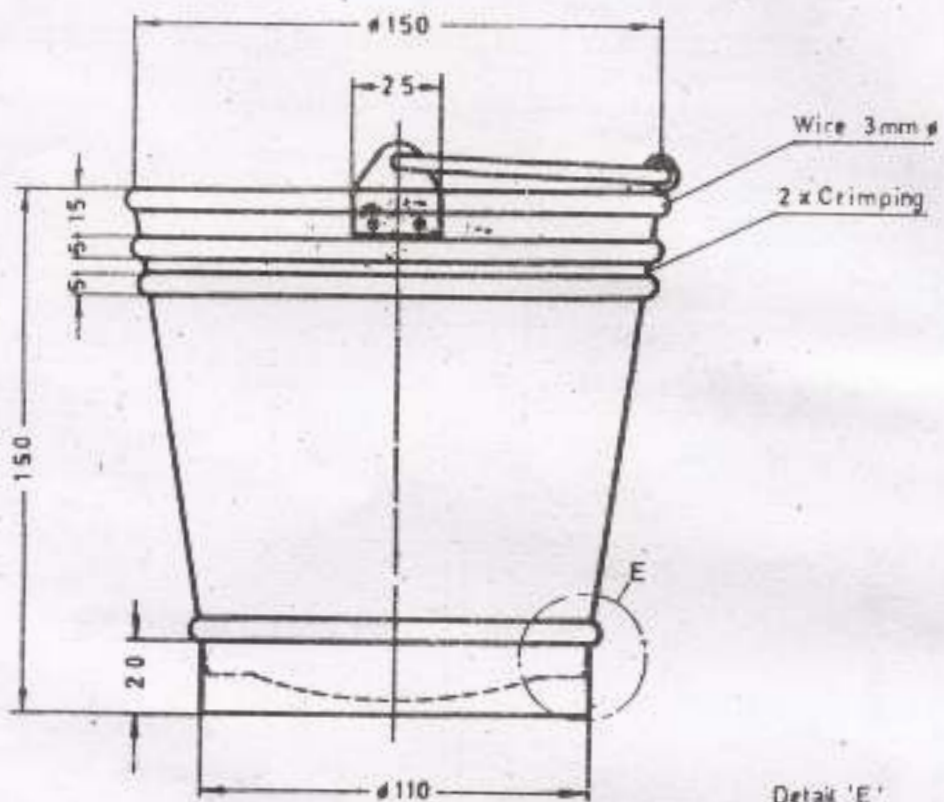

Detail 'E'
Scale 2:1

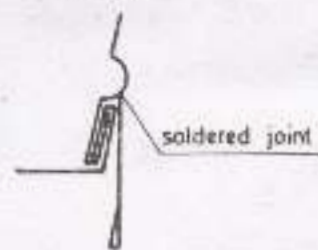

Task:

Draw the bucket in full size on a larger sheet.
Prepare the developments of all its parts.

Scale 1:1	BUCKET	Developments
Date	Name	WELDER
 DEVELOPMENT CELL FOR SKILLED LABOUR TRAINING MAK-GERMAN TECHNICAL TRAINING PROGRAMME		Technical Drawing No.16

Type of welding seam	Representation		Symbol	Type of welding seam	Representation		Symbol	Type of welding seam	Representation		Symbol	Type of welding seam	Representation		Symbol
	Pictorial	Symbolic			Pictorial	Symbolic			Pictorial	Symbolic			Pictorial	Symbolic	
edge weld			L	J-weld			l	edge weld			L	V-weld with seam series			P
open butt weld			II	double J-weld			K	edge fillet weld			L	single fillet weld			L
root-weld			V	flush edge weld			III	edge groove			M	single fillet weld convex			L
open stress plate weld			L	edge groove			M	edge groove			M	single fillet weld concave			L
double root-weld			X	edge fillet weld			L	single fillet weld			L	finished to smooth contour by grinding			T
V-weld			Y	double fillet weld			L	single fillet weld			L	finished to smooth contour by grinding			T
double T-weld			X	edge fillet weld			L	single fillet weld			L	finished to smooth contour by grinding			T
U-weld flared weld			U	double fillet weld			L	double fillet weld			L	finished to smooth contour by grinding			T
double U-weld double flared weld			X	corner fillet weld			L	corner fillet weld			L	finished to smooth contour by grinding			T
edge seam weld			L	three plates weld seam			-	three plates weld seam			-	single fillet continuous weld			L
double seam weld			L	U-seam with V-bore weld			K	U-seam with V-bore weld			K	flat weld at angle			L
double seam weld			L	M V-seam with double fillet weld			L	M V-seam with double fillet weld			L	edge weld			L
K-weld			K	K-seam with double fillet weld			K	K-seam with double fillet weld			K	edge weld			L

WELDING SYMBOLS as in DIN 1912

WELDER



DEVELOPMENT CELL FOR SKILLED LABOUR TRAINING

FAK GERMAN TECHNICAL TRAINING PROGRAMME

Technical Drawing No. 17

Continuous Weld
If the symbols are not indicated continuously a respective sign (arrow) has to be entered

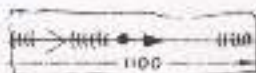

Joints which are to be welded on the construction site are to be indicated by a small flag at the symbol

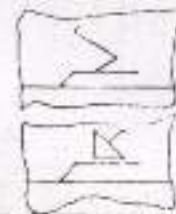

Discontinuous Weld
Discontinuous fillet weld

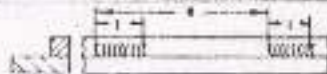

Discontinuous double fillet weld staggered

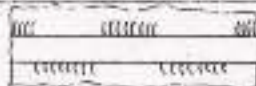

Sequence of welds **Welding direction**

Discontinuous double fillet weld parallel

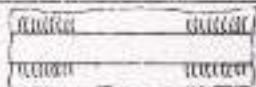

The numbers inside the squares indicate the sequence of welds the welding direction is shown by means of arrows



		Pictorial	Symbolic
Double Vee Weld Thickness of weld = thickness of sheet $a = 20$ mm Bearing length of weld $L = 3000$ mm Arc welding: E. Quality class I			
Single Fillet Weld Continuous Thickness of weld $a = 8$ mm Length of weld $L = 1000$ mm Finished to smooth contour by grinding			
Double Fillet Weld Discontinuous Parallel Thickness of weld visible $a = 6$ mm invisible $a = 8$ mm Number of single welds $n = 5$ pitch $s = 800$ mm Length of single weld $L = 300$ mm			
Double Fillet Weld Discontinuous Staggered Thickness of weld visible $a = 8$ mm invisible $a = 6$ mm Number of single welds $n = 10$ pitch $s = 450$ mm Length of weld $L = 1500$ mm			
Butt Joint		Cross-Joint	
lap Joint		Staggered Joint	
Parallel Joint		Corner Joint	
Tee Joint		Multiple Joint	

REPRESENTATION OF WELDED JOINTS

WELDER



DEVELOPMENT CELL FOR SKILLED LABOUR TRAINING

PAK-GERMAN TECHNICAL TRAINING PROGRAMME

Technical Drawing
No. 18

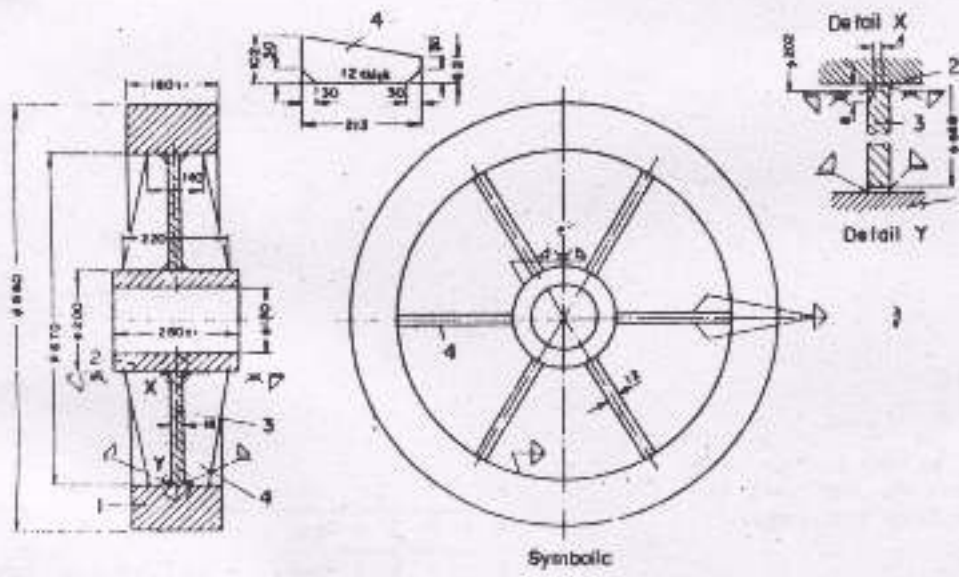
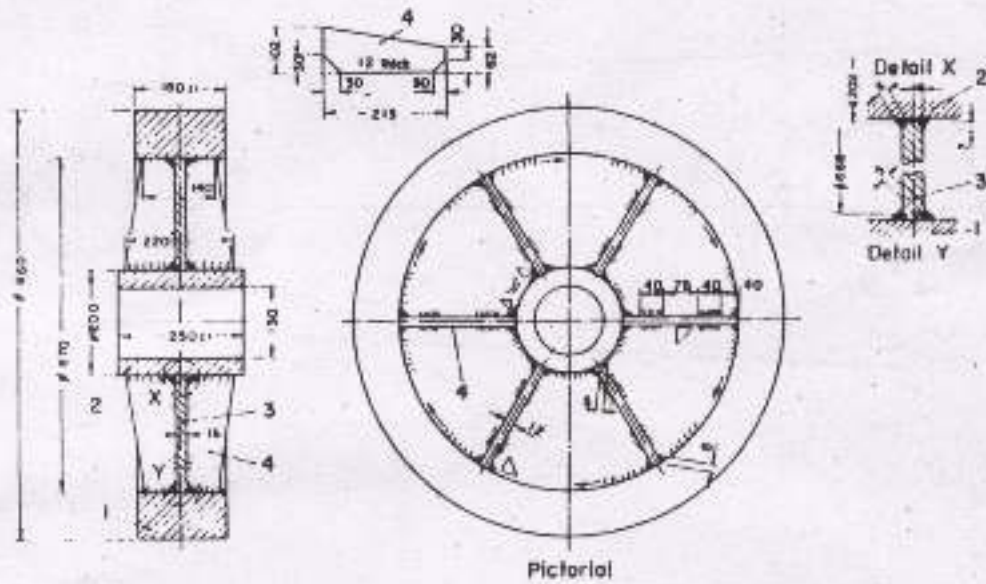

WELDING SYMBOLS IN APPLICATION		WELDER
	DEVELOPMENT CELL FOR SKILLED LABOUR TRAINING	
	PAK-GERMAN TECHNICAL TRAINING PROGRAMME	
		Technical Drawing No. 19

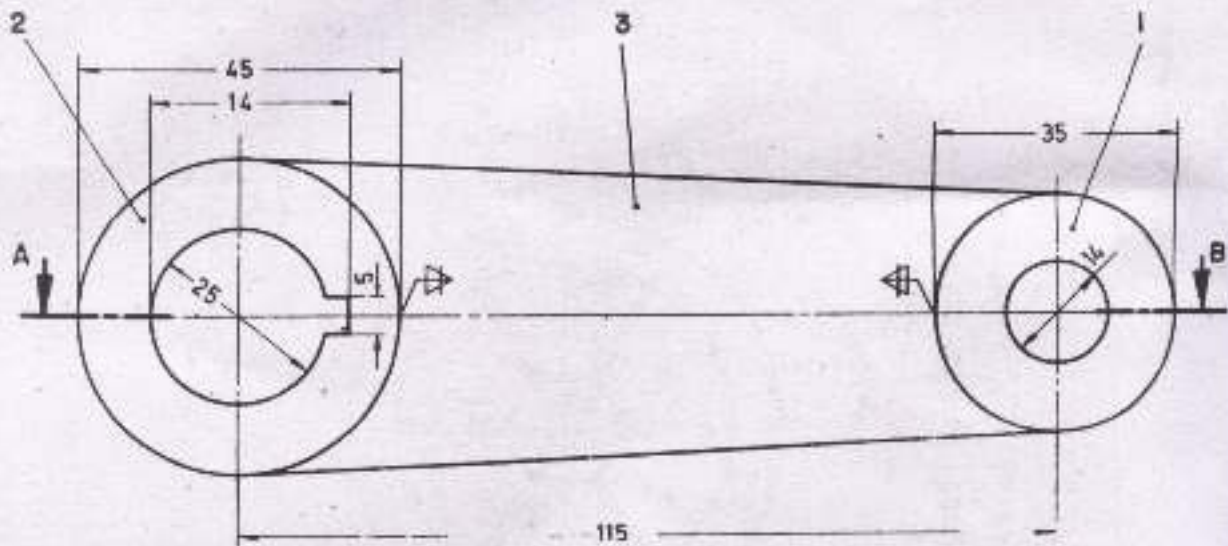

Task:

Draw the section A-B with the fillet weld in pictorial representation.

1	3	Plate	45 x 115 x 5
1	2	Round bar	45/25 ϕ x 25 long
1	1	Round bar	35/14 ϕ x 25 long
No. REQD.	PART No.	DESIGNATION , SIZES	

Scale 1:1	LEVER	Welded Parts
Date	Name	WELDER
 DEVELOPMENT CELL FOR SKILLED LABOUR TRAINING PAK-GERMAN TECHNICAL TRAINING PROGRAMME		Technical Drawing No. 20

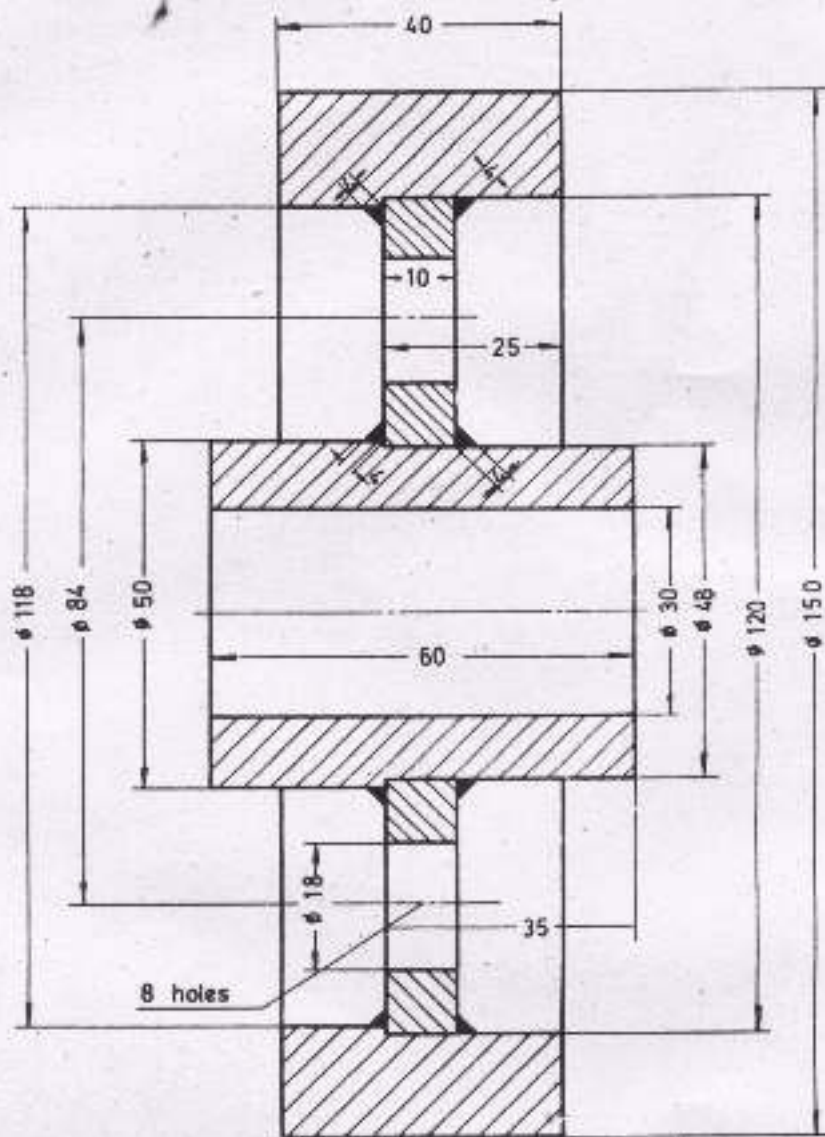

Task:

Draw the side view of the gear blank on sheet No.21,2 with the welds in symbolic representation. Complete the list of parts.

Scale 1:1	WELDED GEAR BLANK	Welded parts
Date	Name	WELDER
 DEVELOPMENT CELL FOR SKILLED LABOUR TRAINING PAK-GERMAN TECHNICAL TRAINING PROGRAMME		Technical Drawing No. 21,1

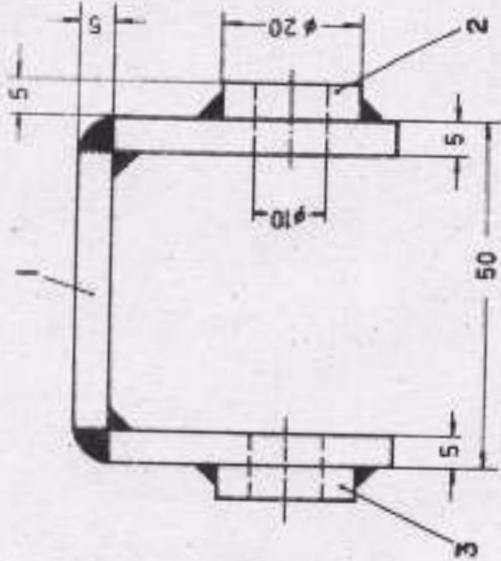
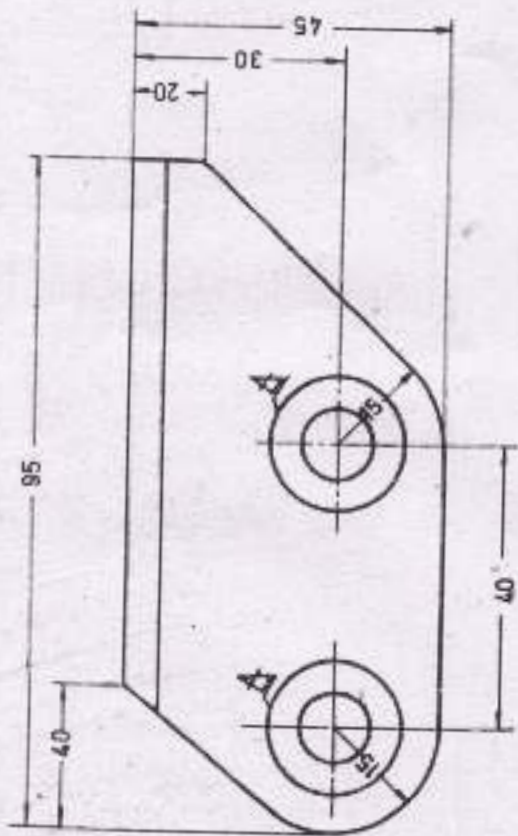

Task:

Draw the plan view of the Spring Bracket with the weld in symbolic representation. Complete the list of parts by entering designation and raw sizes.

No.	PART	DESIGNATION	SIZES	MAT.

Scale 1:1	SPRING BRACKET	Welded Parts
Date		WELDER
 DEVELOPMENT CELL FOR SKILLED LABOUR TRAINING PAK-GERMAN TECHNICAL TRAINING PROGRAMME		Technical Drawing No. 22

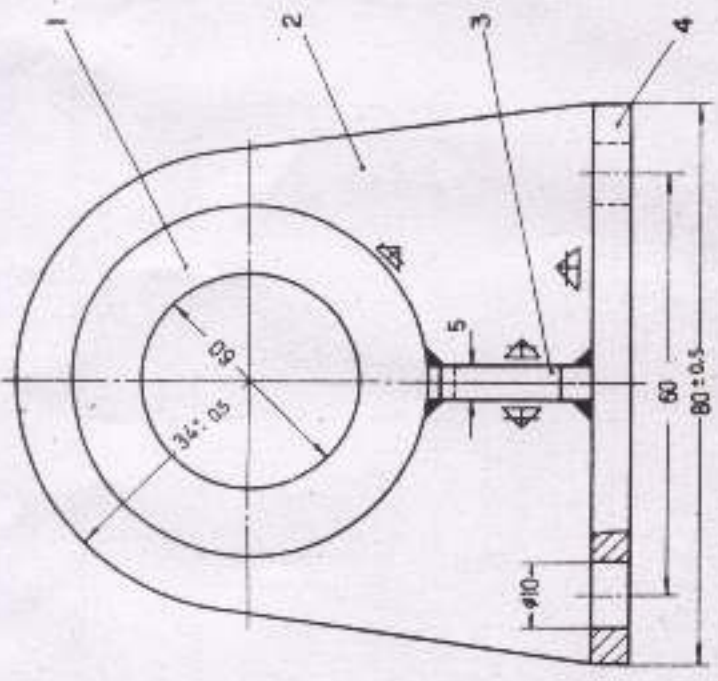
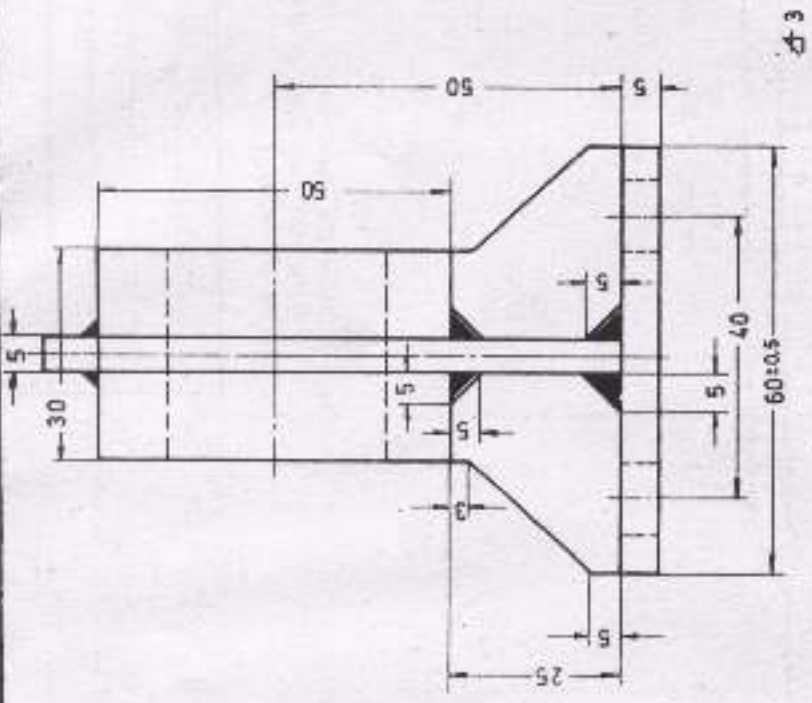

Task:

Draw the plan view with welds in pictorial representation. Complete the list of parts by entering designation and sizes.

No.	PART REQD.No.	DESIGNATION, SIZES	MAT.

Scale 1:1

BEARING

Welded Parts

Date

Name

WELDER



DEVELOPMENT CELL FOR SKILLED LABOUR TRAINING

PAK-GERMAN TECHNICAL TRAINING PROGRAMME

Technical Drawing No. 23

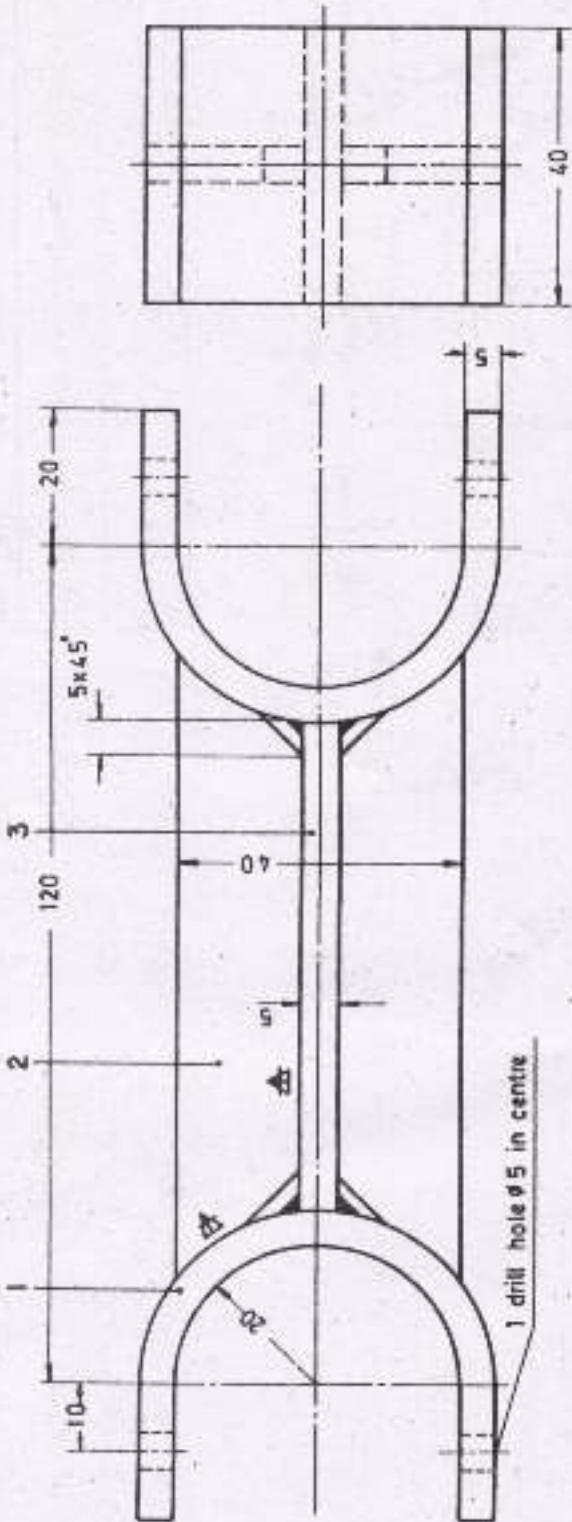

A3

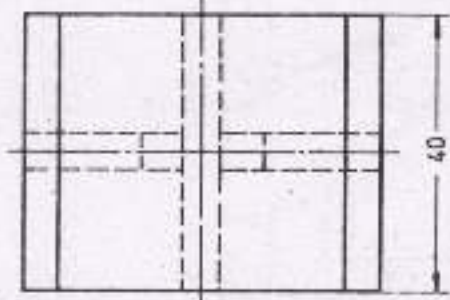

Task

Draw the plan view
Enter the raw sizes in the
below table.

No.	PART				SIZES
REQD	No.				

Scale	LEVER	Welded Parts
Date	Name	WELDER



DEVELOPMENT CELL FOR SKILLED LABOUR TRAINING

PAK-GERMAN TECHNICAL TRAINING PROGRAMME

Technical
Drawing
No. 24

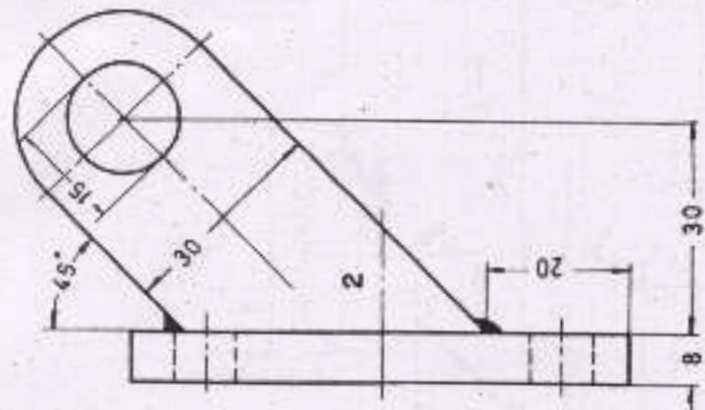

Task
Draw the plan view.

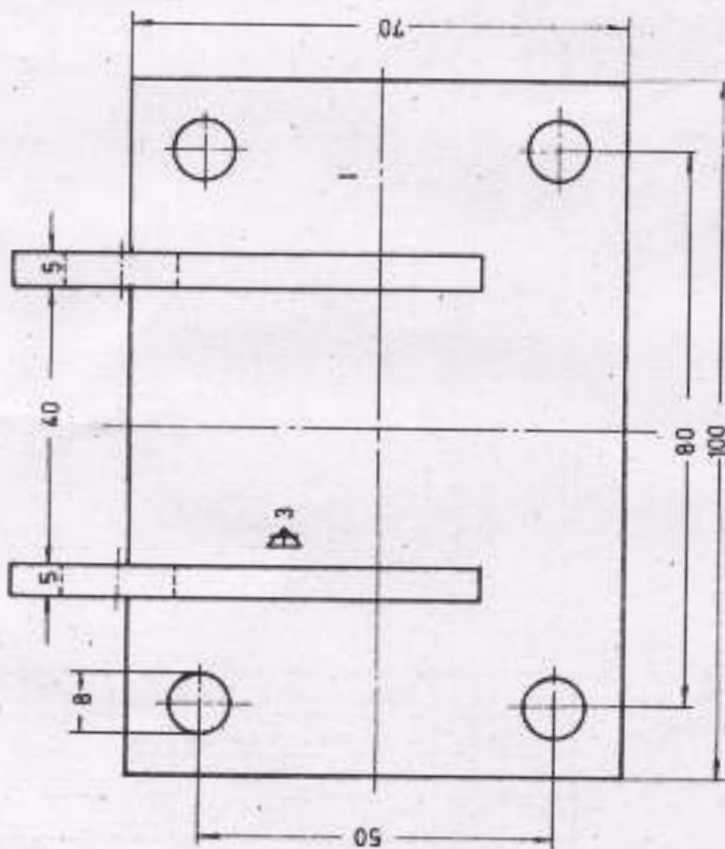

Scale 1:1	BRACKET	Welded Parts
Date	Name	WELDER
 DEVELOPMENT CELL FOR SKILLED LABOUR TRAINING PAK-GERMAN TECHNICAL TRAINING PROGRAMME		Technical Drawing No 25

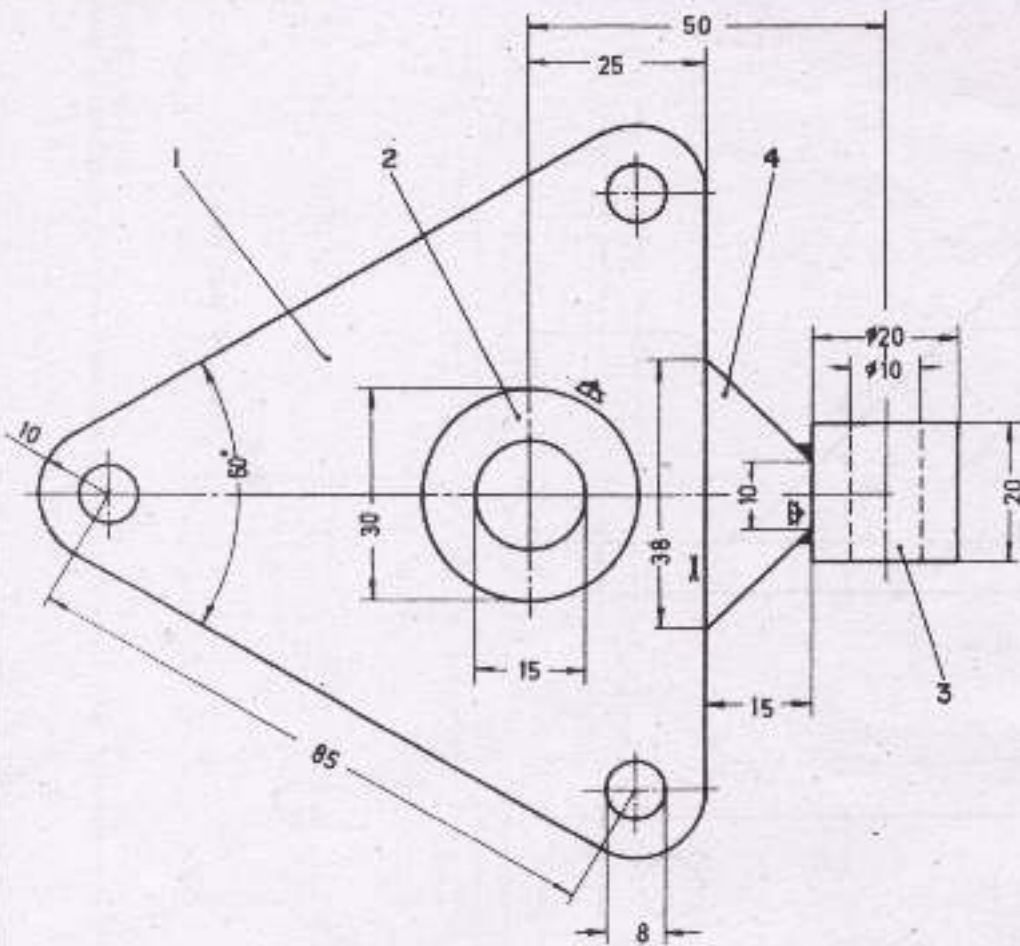

Task:

Draw the side view and the plan view of workpiece with missing dimensions.

Enter the welding symbols where required.

Thickness of welds 3 mm

1	4	Plate	∅40 x 30 x 6
1	3	Iron bar	∅ 20 x 20 long
1	2	Iron bar	∅ 30 x 20 long
1	1	Plate	110 x 10 x 6
No. REQD	PART No.	DESIGNATION, SIZES	

Scale 1:1	FLANGE BEARING	Welded Parts
Date	Name	WELDER
 DEVELOPMENT CELL FOR SKILLED LABOUR TRAINING <small>PAK-GERMAN TECHNICAL TRAINING PROGRAMME</small>		Technical Drawing No. 26

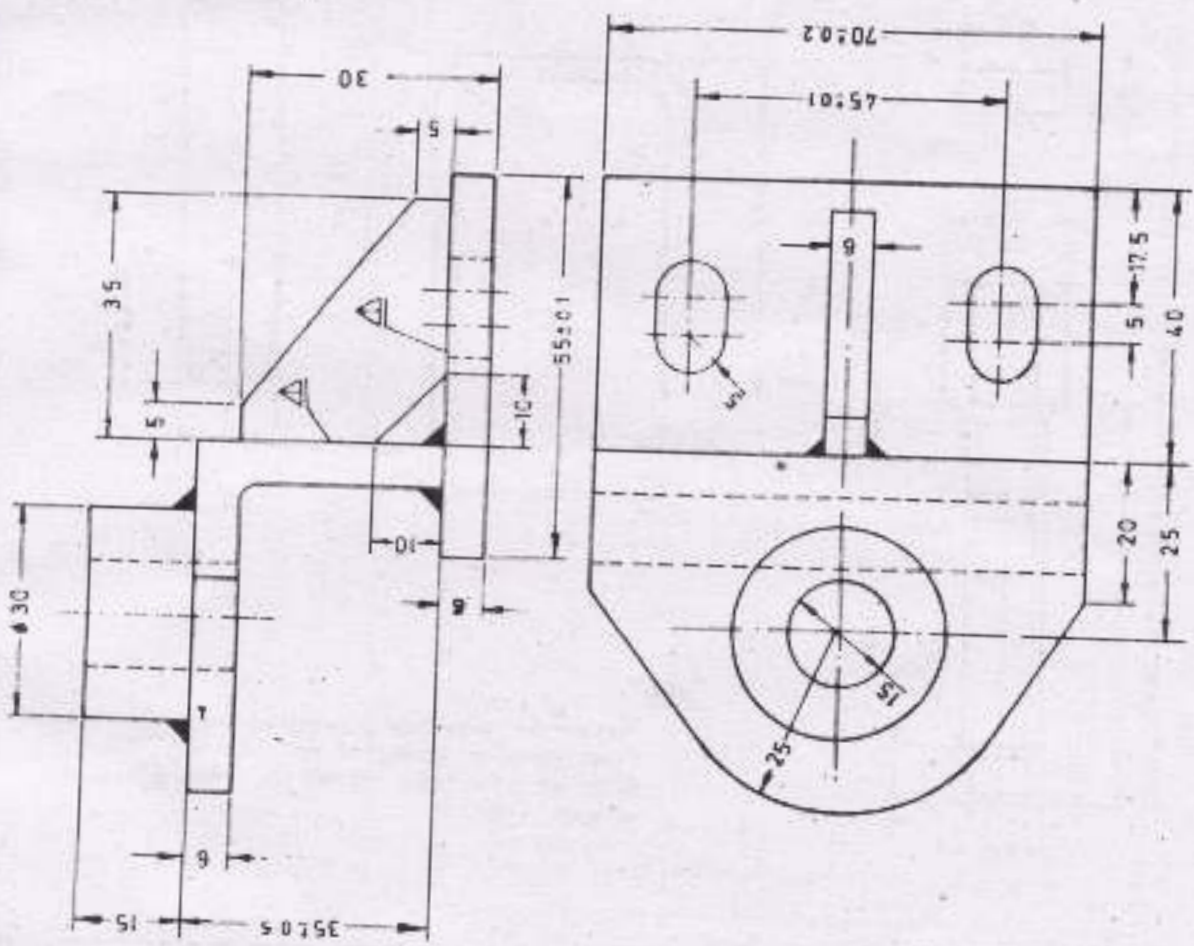

Task:
 Draw the side view of the angle support.
 Indicate that the thickness of welds is 4 mm.

Scale 1:1	ANGLE SUPPORT		Welded Parts
Date	Name		WELDER
 DEVELOPMENT CELL FOR SKILLED LABOUR TRAINING <small>PAK GERMAN TECHNICAL TRAINING PROGRAMME</small>			Technical Drawing No. 27

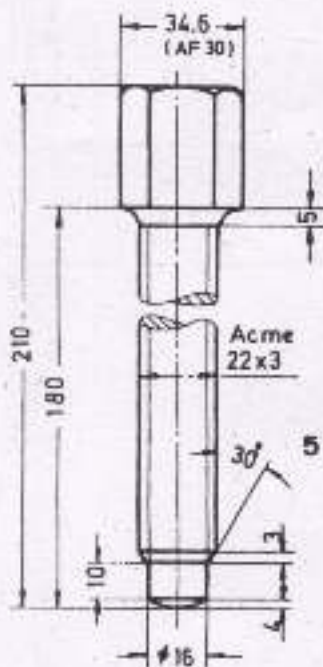
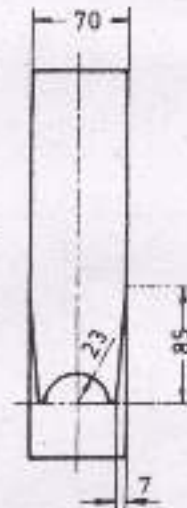
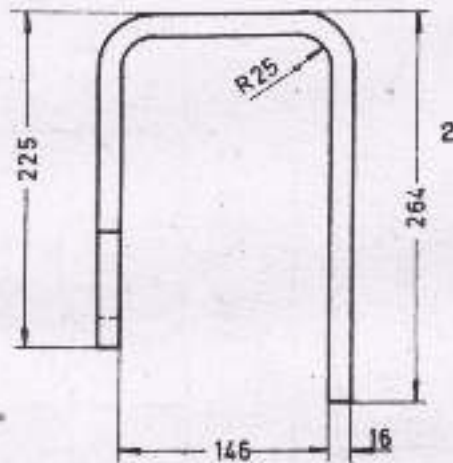
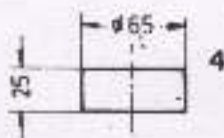
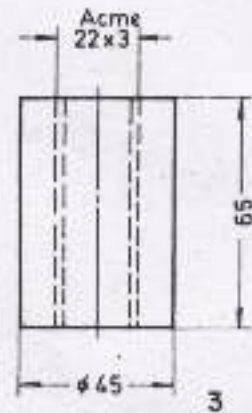
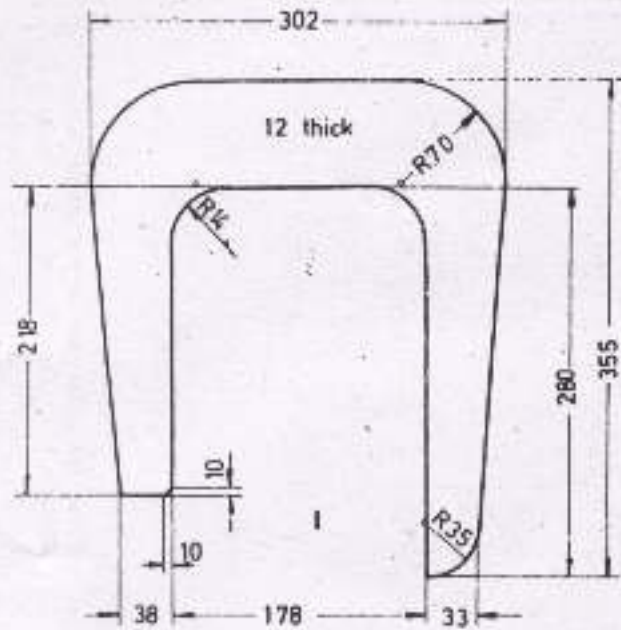

Task

Prepare the assembly drawing of the screw clamp (three views) in scale 1:5 on sheet No. 28.2. Enter all information required for welding (thickness of welds 4 mm).

Scale	WELDED SCREW CLAMP	Welded Parts
Date	Name	WELDER
 DEVELOPMENT CELL FOR SKILLED LABOUR TRAINING PAK-GERMAN TECHNICAL TRAINING PROGRAMME		Technical Drawing No. 28.1

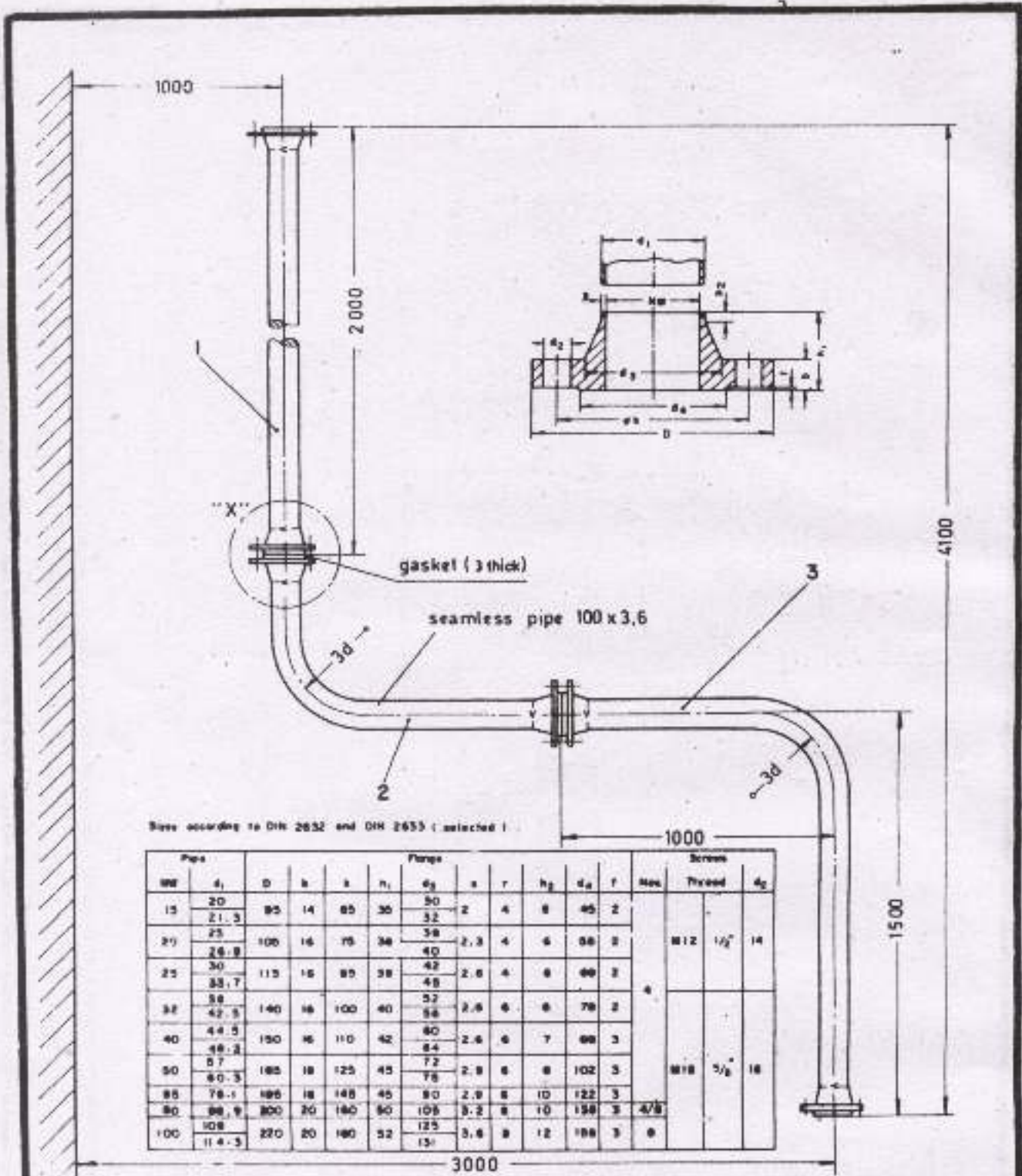

Task:

- 1 Draw detail "X" in full scale.
- 2 Calculate the total length of the pipes 1,2 and 3.

Scale	PIPE LINE		Welded Parts
Date	Name		WELDER
 DEVELOPMENT CELL FOR SKILLED LABOUR TRAINING PAK-GERMAN TECHNICAL TRAINING PROGRAMME			Technical Drawing No. 29.1

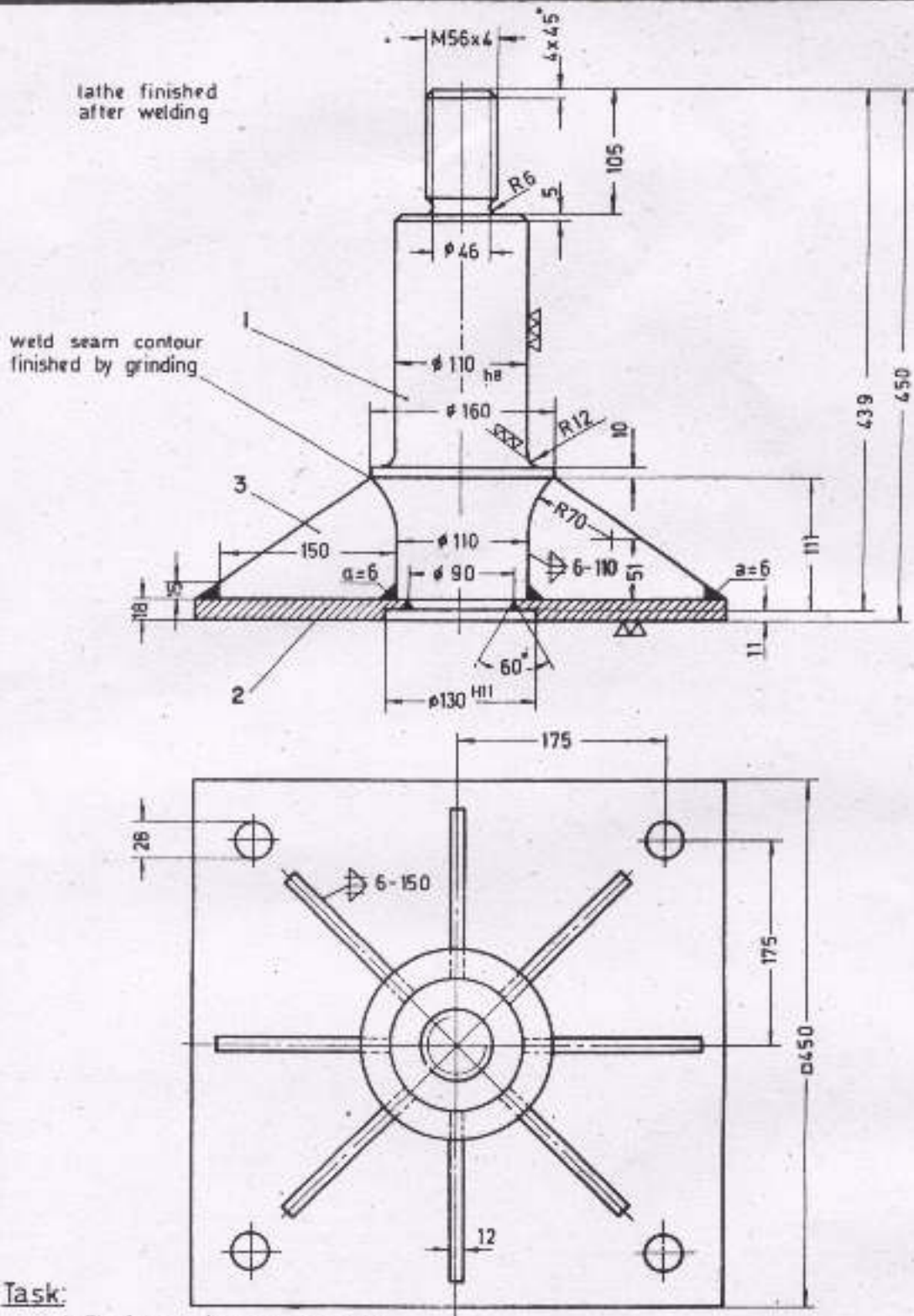

Task:

1. Fill in the list of parts with:
Part No., No. reqd., designation, raw sizes and material.
2. Prepare detail drawings of all parts (scale 1:5).

Scale 1:5	PIVOT	Welded Parts
Date	Name	WELDER
 DEVELOPMENT CELL FOR SKILLED LABOUR TRAINING <small>FAK GERMAN TECHNICAL TRAINING PROGRAMME</small>		Technical Drawing No.30.1

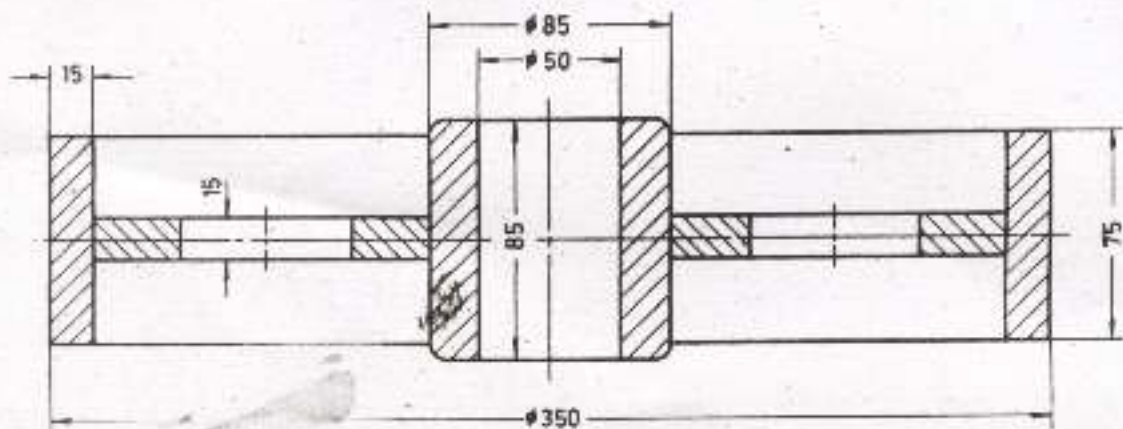
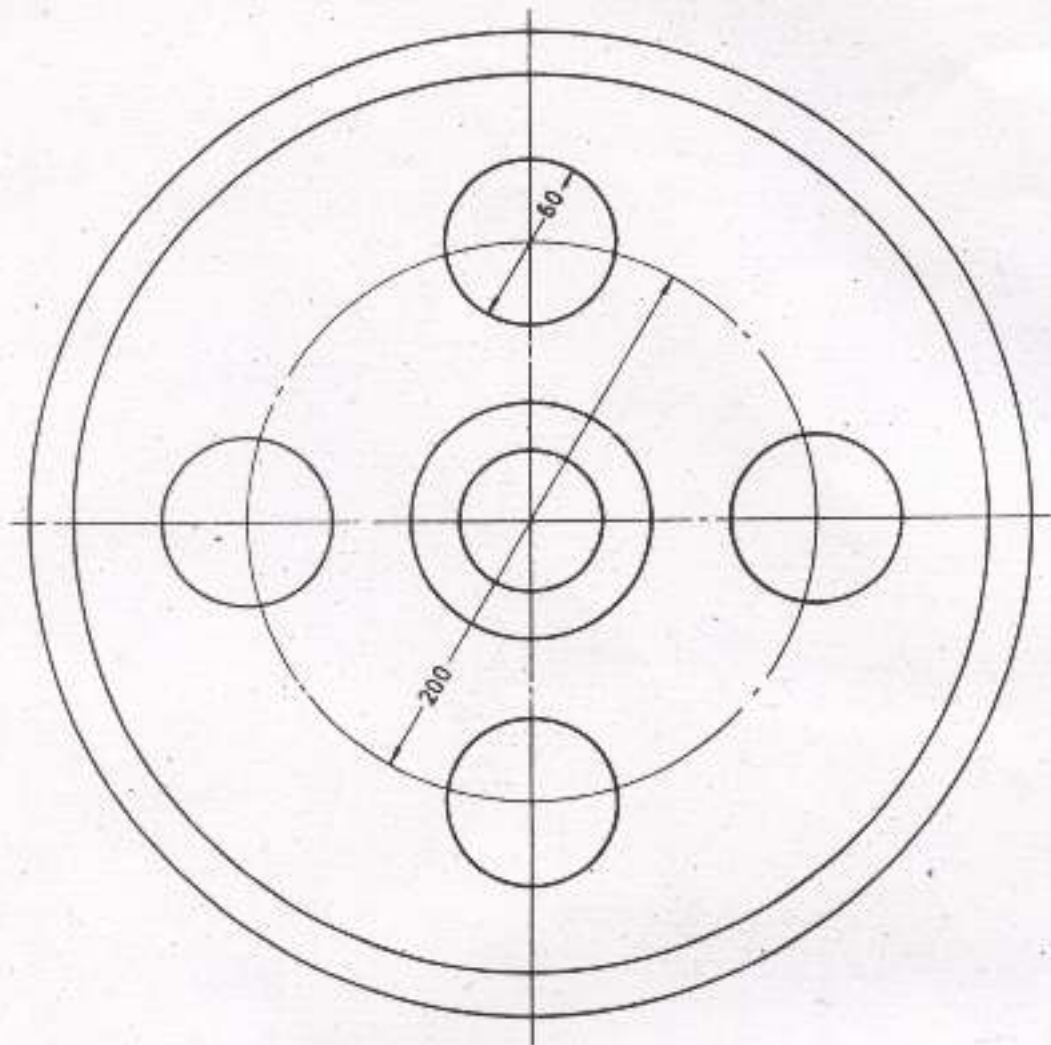

Task:

Enter the welding symbols (symbolic representation continuous double fillet weld, 4 mm)

Scale 1:2,5	BRAKE DISK	Welded Parts
Date	Name	WELDER
 DEVELOPMENT CELL FOR SKILLED LABOUR TRAINING <small>F&K GERMAN TECHNICAL TRAINING PROGRAMME</small>		Technical Drawing No. 31

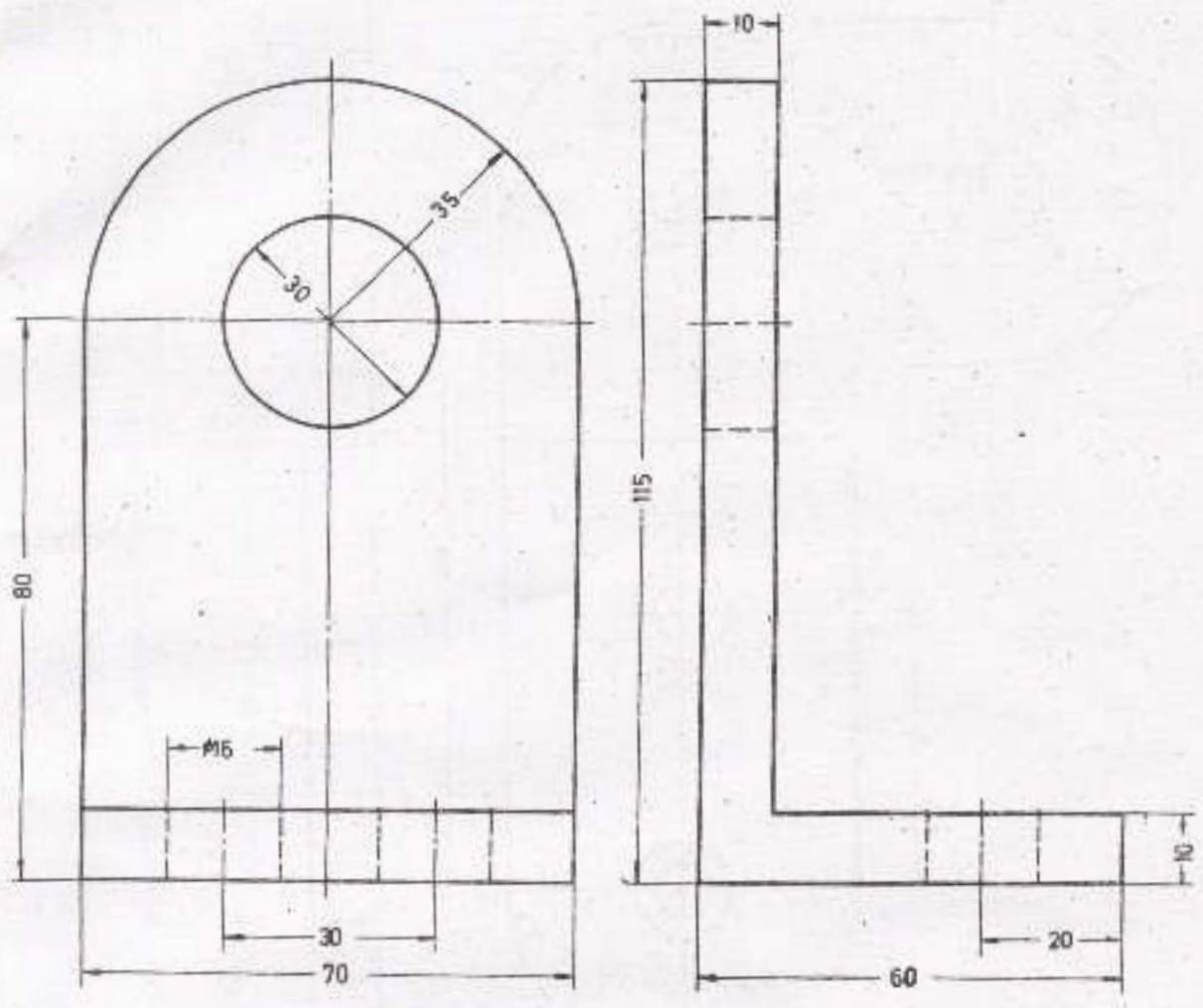

Task:

1. Draw the plan view.
2. Change the side view into a sectional view and indicate in pictorial representation that the workpiece consists two parts, choose a suitable type of weld.
3. Fill in the list of parts with raw sizes.

No. REQD.	PART No.	DESIGNATION, SIZES

Scale 1:1	CLAMPING PLATE	Welded Parts
Date	Name	WELDER
 DEVELOPMENT CELL FOR SKILLED LABOUR TRAINING PAK-GERMAN TECHNICAL TRAINING PROGRAMME		Technical Drawing No. 32

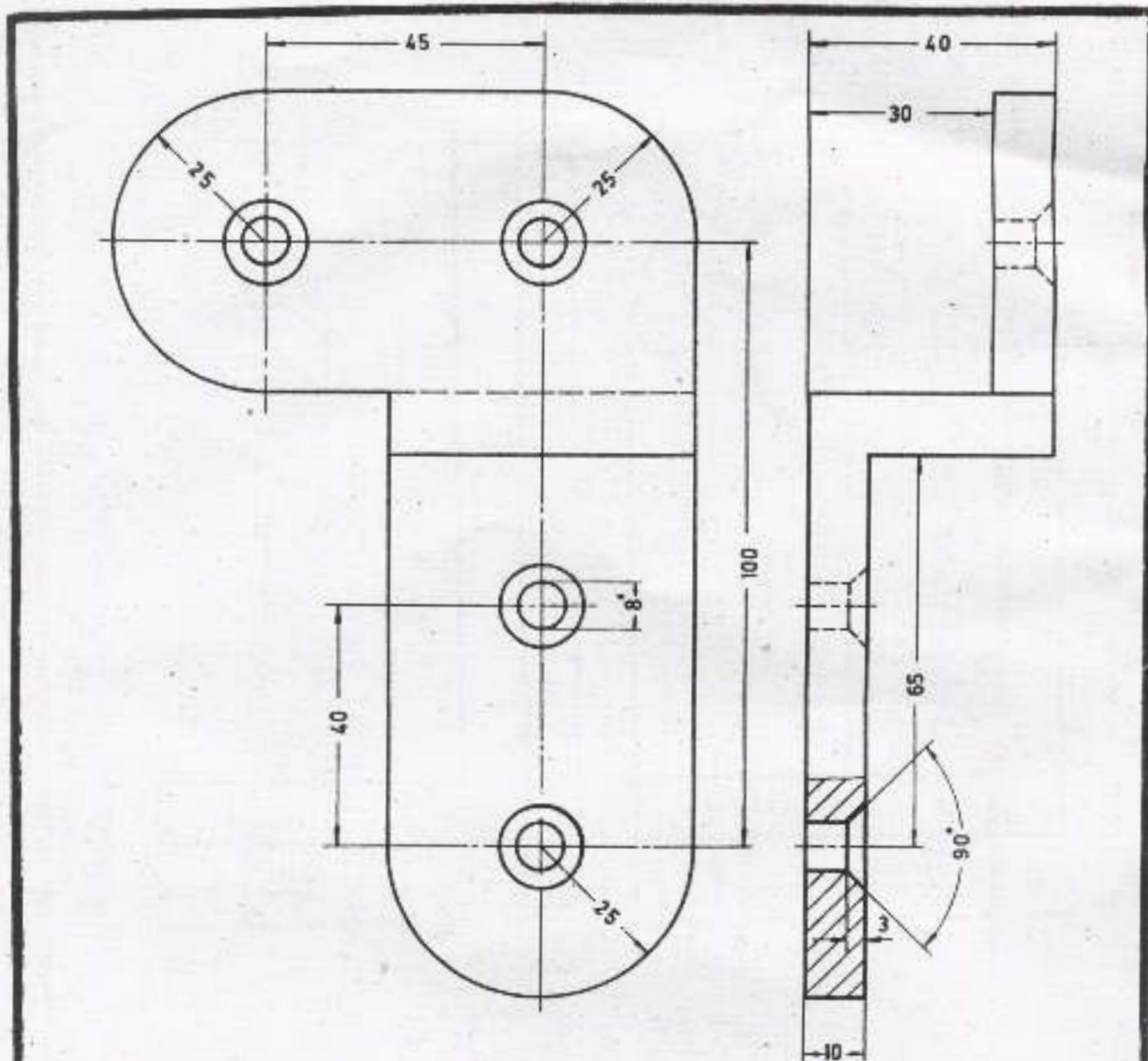

Task:

1. Draw the plan view.
2. Indicate in symbolic representation that the workpiece consists of three parts, welded together (choose suitable types of welds).
3. Fill in the list of parts including raw sizes.

No REQD	PART No	DESIGNATION, SIZES

Scale 1:1	ANGLE	Welded Parts
Date	Name	WELDER

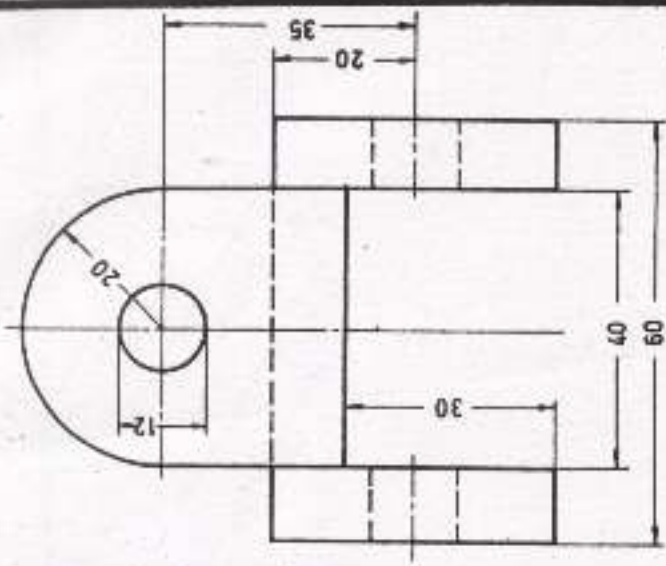
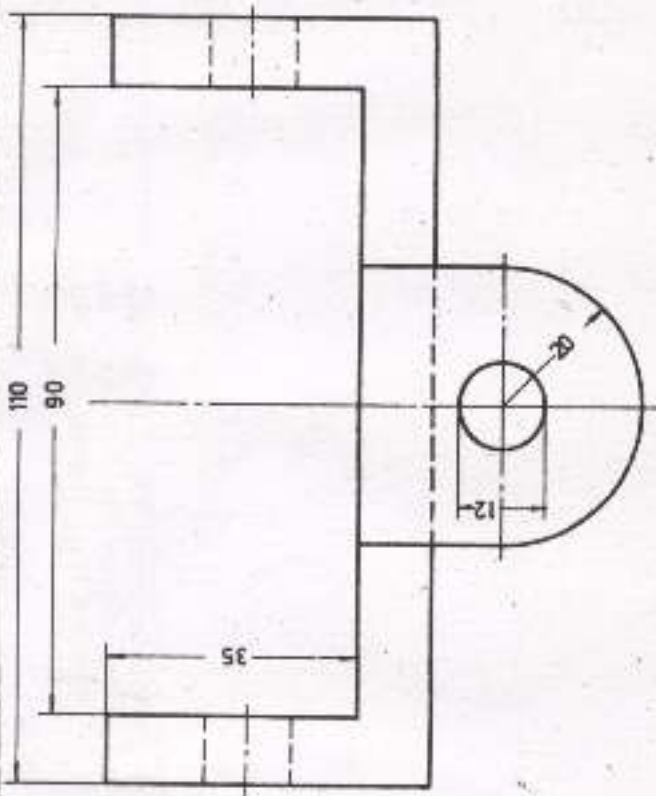

Task

1. Draw the plan view.
2. The workpiece consists of three parts welded together. Choose suitable types of welds and indicate them in pictorial representation in the drawing.
3. Fill in the list of parts.

No. REQD.	DESIGNATION	PART No.	SIZES	MATERIAL	
Scale 1:1	BRACKET			Welded Parts	
Date	Name			WELDER	
 DEVELOPMENT CELL FOR SKILLED LABOUR TRAINING PAK-GERMAN TECHNICAL TRAINING PROGRAMME				Technical Drawing No. 34	

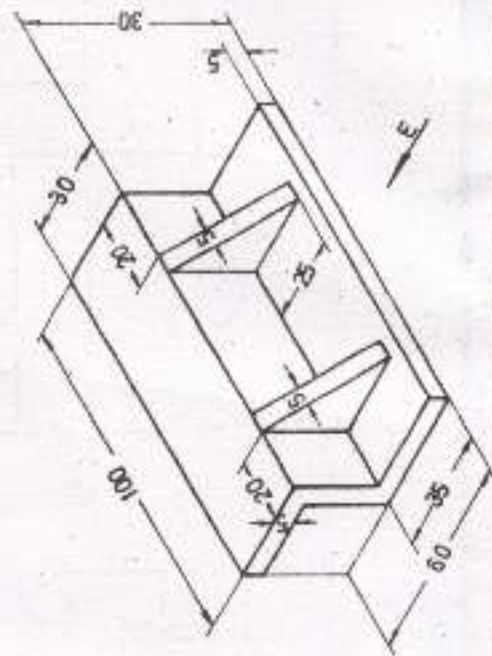

Task:

1. Draw the three views in full size with dimensions.
2. The "Z" is a welded structure that consists of three pieces of flat steel and two triangular ribs. Choose suitable types of welds and indicate them in symbolic representation.

Scale 1:1	WELDED 'Z'	Welded Parts
Date	Name	WELDER
 DEVELOPMENT CELL FOR SKILLED LABOUR TRAINING PAK-GERMAN TECHNICAL TRAINING PROGRAMME		Technical Drawing No. 35

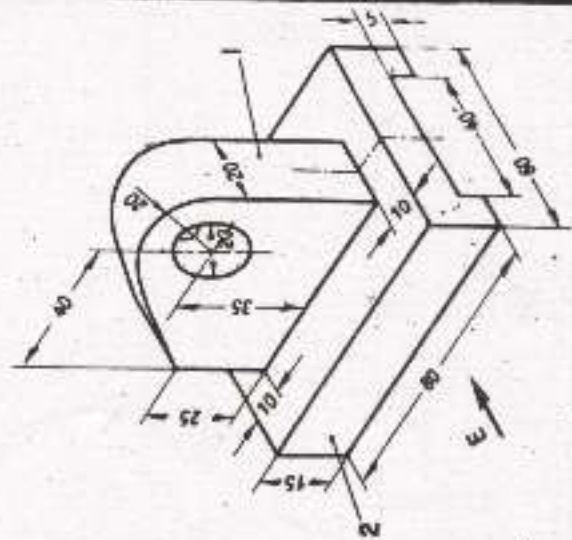

- Task:**
1. Draw the three views in full size with dimensions.
 2. The workpiece consists of two parts welded together. Choose suitable types of welds and indicate them in the drawing (pictorial representation).

Scale 1:1	EYE TYPE BEARING	Welded Parts
Date	Name	WELDER
	DEVELOPMENT CELL FOR SKILLED LABOUR TRAINING	
	PAK-GERMAN TECHNICAL TRAINING PROGRAMME	
		Technical Drawing No. 36

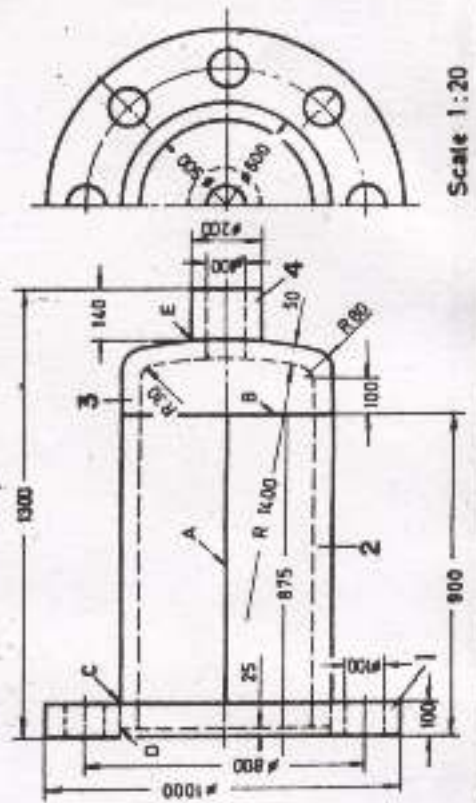

Task:

1. Draw the Pressure Tank to scale 1 : 10
 - Elevation as sectional view.
 - Side view as given
 - with all dimensions required
2. Indicate welds in symbolic representation.
 - Thickness of welds: 10 mm
 - Weld A & B : Vee weld!
 - Weld C, D & E : Fillet weld!

Scale 1 : 20 1 : 10	HIGH PRESSURE TANK	Welded Parts
Date	Name	WELDER
 DEVELOPMENT CELL FOR SKILLED LABOUR TRAINING PAK-GERMAN TECHNICAL TRAINING PROGRAMME		Technical Drawing No. 37

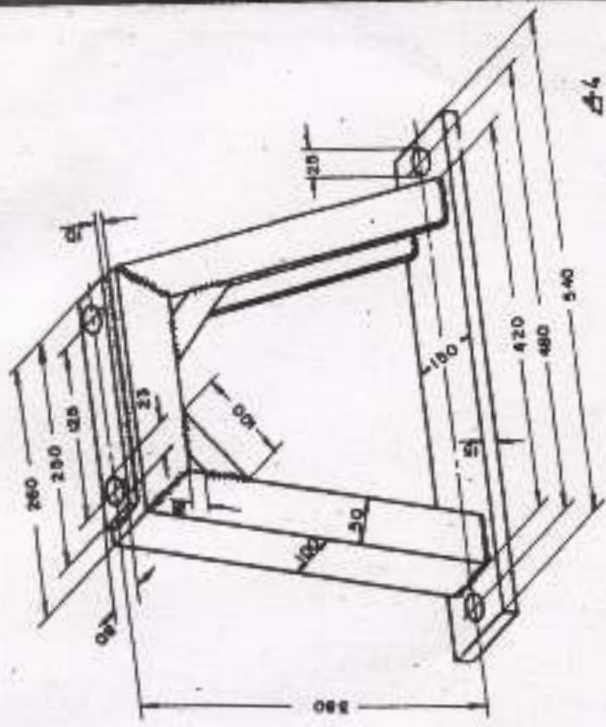

Task:

Draw the elevation and plan view to scale 1:5 with all dimensions and all information required for welding (symbolic representation).

1	4	M. S. Plate	240x80x10
4	3	M. S. Plate	100x29x5
1	2	M. S. Channel iron	100x50x5x1050
1	1	M. S. Plate	150x540x15
No. REQD.	PART No.	DESIGNATION, SIZES	

Scale 1:5	WELDED STAND	Welded Parts
Date	Name	WELDER
 DEVELOPMENT CELL FOR SKILLED LABOUR TRAINING PAK-GERMAN TECHNICAL TRAINING PROGRAMME		Technical Drawing No. 38

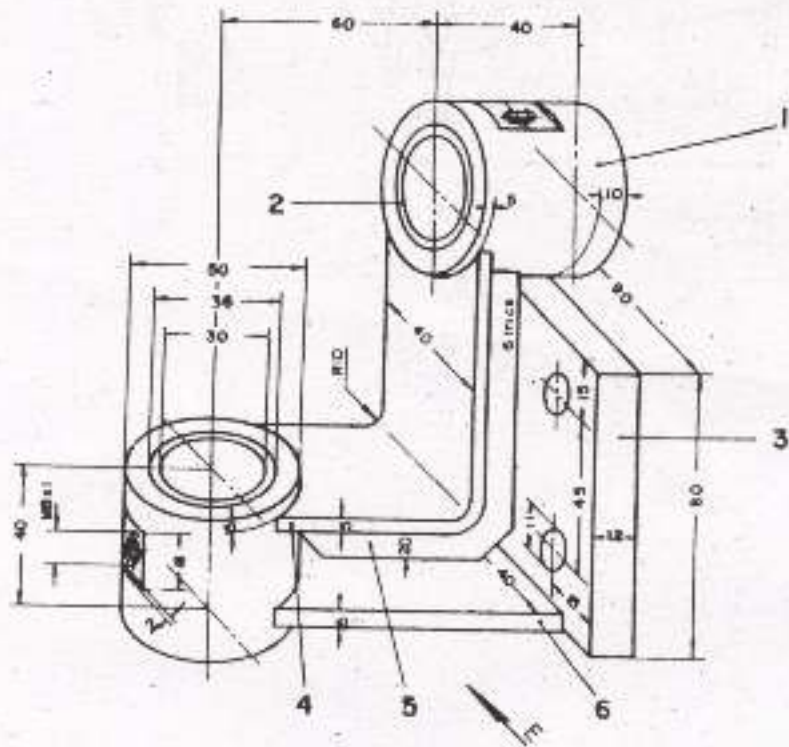

Task: See sheet No. 39.21

Scale	ANGULAR BEARING	Welded Parts
Date	Name	WELDER
 DEVELOPMENT CELL FOR SKILLED LABOUR TRAINING <small>PAN-GERMAN TECHNICAL TRAINING PROGRAMME</small>		Technical Drawing No. 39.1

Task

1. Draw elevation and side view (scale 1:1) with all dimensions and information required for welding (symbolic representation). Side view represented as half view.
2. Fill in the list of parts.

Scale 1:1	ANGULAR BEARING	Solution
Date	Name	WELDER
	DEVELOPMENT CELL FOR SKILLED LABOUR TRAINING PAK-GERMAN TECHNICAL TRAINING PROGRAMME	Technical Drawing

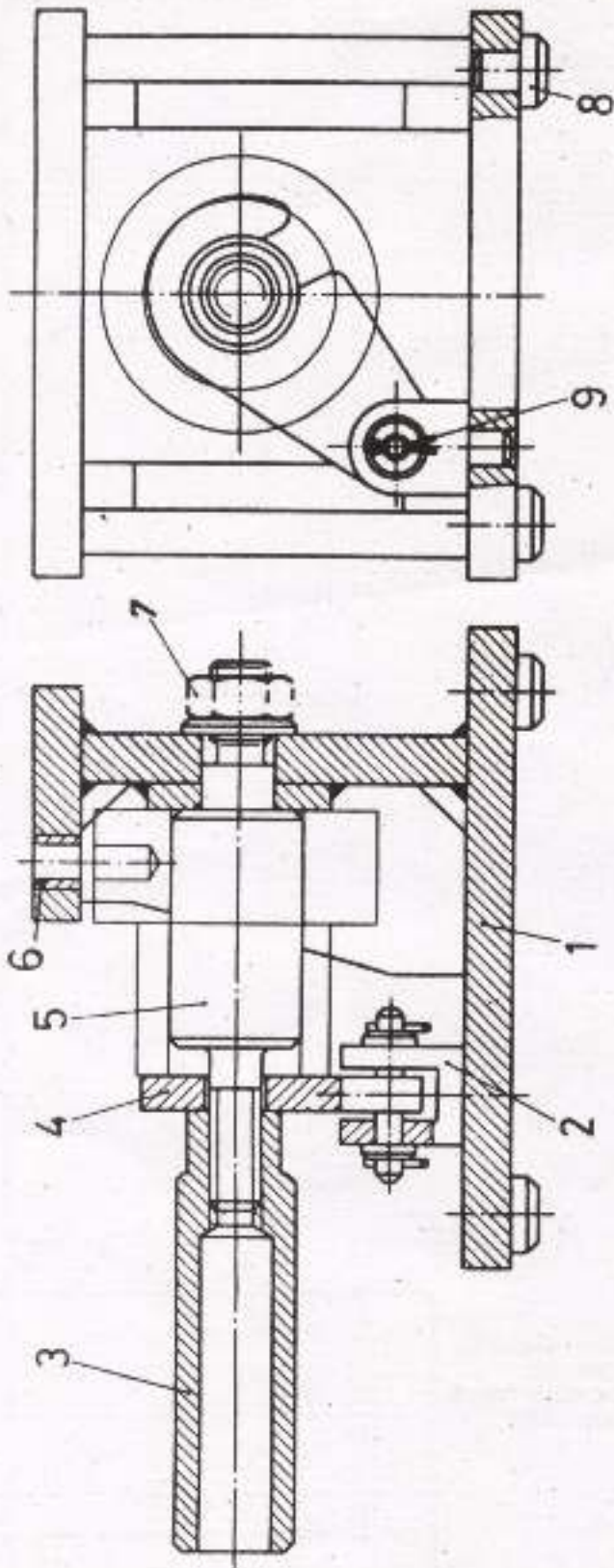

Scale 1:2,5	DRILLING JIG	Welded Parts
Date	Name	WELDER
 DEVELOPMENT CELL FOR SKILLED LABOUR TRAINING PAK-GERMAN TECHNICAL TRAINING PROGRAMME		Technical Drawing No. 40,1

Task:

Prepare a sub-assembly in two views, showing only those parts which are welded together. Scale 1:2,5, sectional elevation. Enter all informations required for welding (pictorial representation). Prepare complete list of parts.

Scale 1:2,5	DRILLING JIG	Solution
Date	Name	WELDER
	DEVELOPMENT CELL FOR SKILLED LABOUR TRAINING PAK-GERMAN TECHNICAL TRAINING PROGRAMME	Technical Drawing No. 40,2

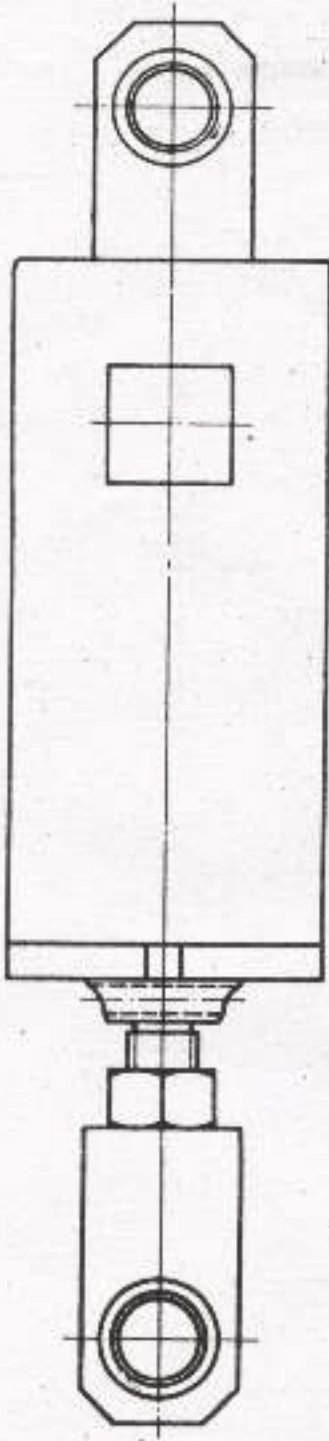
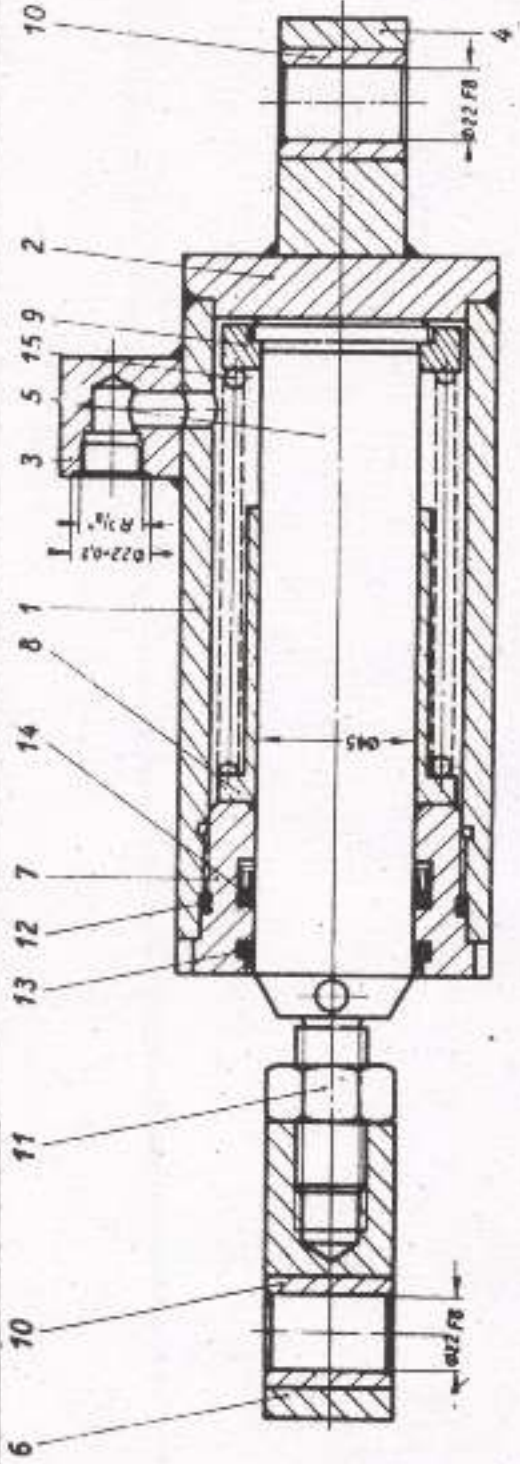

Task:

Prepare a sub-assembly in as many views as necessary, showing only those parts which are welded together (scale 1:1). Enter all dimensions and give the information required for welding (symbolic representation).

No.	PART DESIGNATION	DESIGNATION	SIZES
1	10	Bush	$\phi 35 \times 40$ Sn B z 6
1	9	Ring	$\phi 70 \times 15$ St. 50
1	8	Bush	$\phi 70 \times 90$ St. 50
1	7	Threaded bush	$\phi 32 \times 55$ 05-38
1	6	Connecting rod	$40 \times 50 \times 90$ St. 50
1	5	Piston	$\phi 55 \times 260$ St. 60
1	4	Connecting rod	$45 \times 35 \times 72$ St. 50
1	3	Connecting piece	35×38 St. 37
1	2	Bottom plate	$\phi 90 \times 20$ St. 50
1	1	Cylinder	Pipe $89 \times 10 \times 90$ St. 50

No.	PART DESIGNATION	DESIGNATION	SIZES
1	15	Pressure spring	1648-7
1	14	Oil seal	648-6
1	13	Felt seal	1648-5
1	12	O-Seal	$\phi 3 \times 6.8 \times 7.6$ C 53
1	11	Hexagon nut	M 20 DIN 934 4 D

Scale 1:1	BREAK CYLINDER	Welded Parts
Date		Name
 DEVELOPMENT CELL FOR SKILLED LABOUR TRAINING PAK-GERMAN TECHNICAL TRAINING PROGRAMME		Technical Drawing No. 41.1

